

# ROCK-O-LA 1454

## SERVICE & PARTS MANUAL

FOR

## MODEL 1454 PHONOGRAPH

120 SELECTION HI-FIDELITY

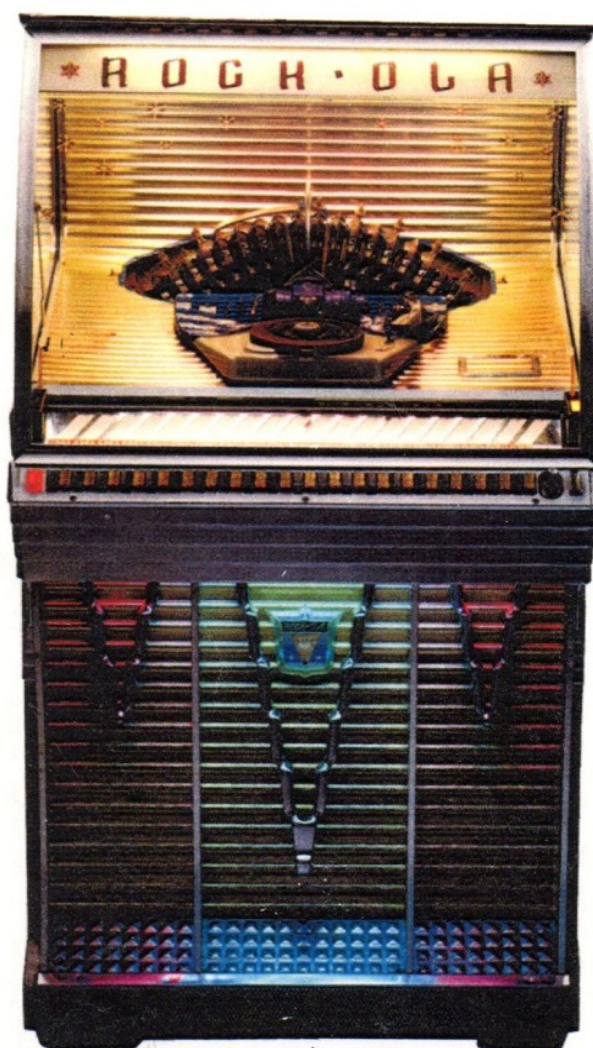



# ROCK-OLA

## INSTALLATION MANUAL

Model 1454

(50 SELECTION HI-FIDELITY)

**ROCK-OLA** *Manufacturing Corporation*

800 N. KEDZIE AVE., CHICAGO 51, ILLINOIS

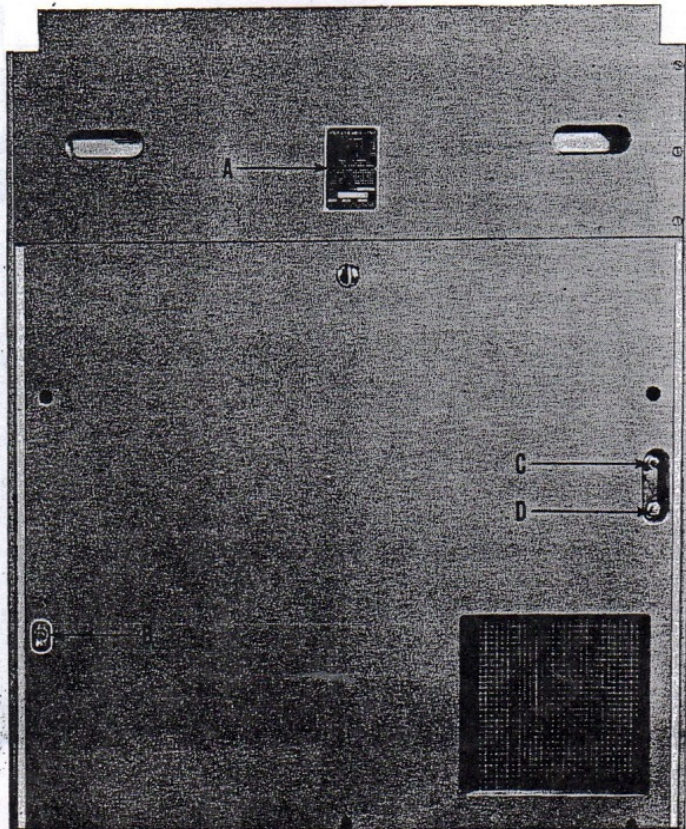

FIG. 1—Rear of Cabinet

### 117 V. LINE CORD

Check location power line outlet before plugging in phonograph. Make certain that outlet provides electrical requirements stamped on serial plate (A-Fig. 1) affixed to rear of phonograph cabinet. Power line should supply 117 volts—60 cycles—275 watts (max.)—single phase.

### POWER AND LIGHT SWITCH

Master line switch (B-Fig. 1) is located on rear of phonograph.

Up position—ON  
Down position—OFF

This switch controls all power to mechanism and lights. If coins are inserted for play credits while master switch is in "OFF" position, credits will not accumulate.

### REJECT SWITCH

Location of this switch is on rear of phonograph (C-Fig. 1). To reject a record that is being played, depress plunger momentarily.

### VOLUME CONTROL

Volume is adjusted by slotted shaft (D-Fig. 1) at rear of phonograph. Use key supplied or small screw driver.

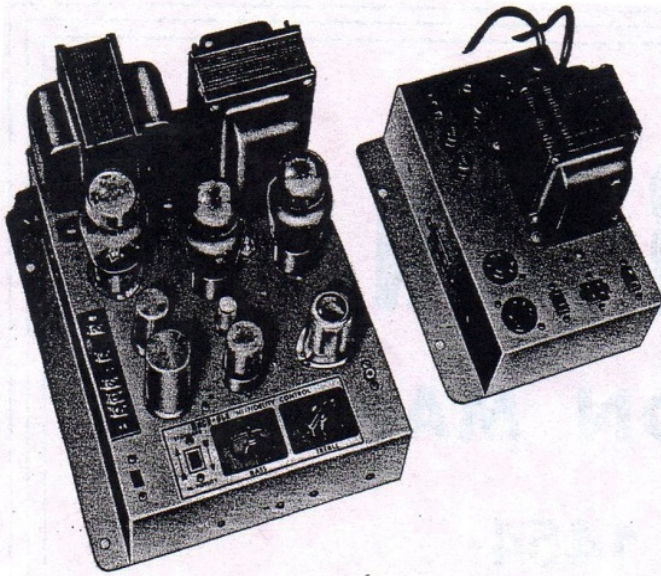

**Fig. 2—View of Amplifier and Power Distribution Panel**

### AMPLIFIER AND POWER PANEL

1. Make sure that tubes are tight in sockets.
2. Check tightness of plugs in receptacles.
3. At no time should tubes be removed from amplifier while phonograph is on.
4. The "START RELAY" and "RECTIFIER" are found on the power panel which contains the power circuits for the entire phonograph.

### LIGHTING EFFECT

1. One 20-watt fluorescent tube supplies lighting to the front door. The tube is shown at (B-Fig. 3). The starter (A-Fig. 3) is located at the right side of the door.
2. Cabinet lighting is accomplished with 20-watt fluorescent tube located in dome at (B-Fig. 4). The fluorescent starter is located at the right side of the tube.

### TO INSTALL TITLE STRIPS

1. To facilitate programing, open front door to full length of both door chains, and raise dome glass.

2. Grasp front door title strip holder (1-40) firmly at both ends and apply slight pressure upward. Tilt bottom of holder outward and remove to install title strips.
3. To remove dome title strip holder (1-10) pull out at right side. Install title strips.

### TO REPLACE NEEDLE

See instruction sheet "Series '51-1J' Ceramic Pick-up Cartridge" packed inside cloth shipping bag.

### TOP DOME ASSEMBLY

The top dome is held in an open position by means of locking latch (A-Fig. 4). The latch bar is held firmly in place by a spring lock which applies pressure against the locking latch.

To close top dome, apply slight pressure inward against locking latch and lower top dome.

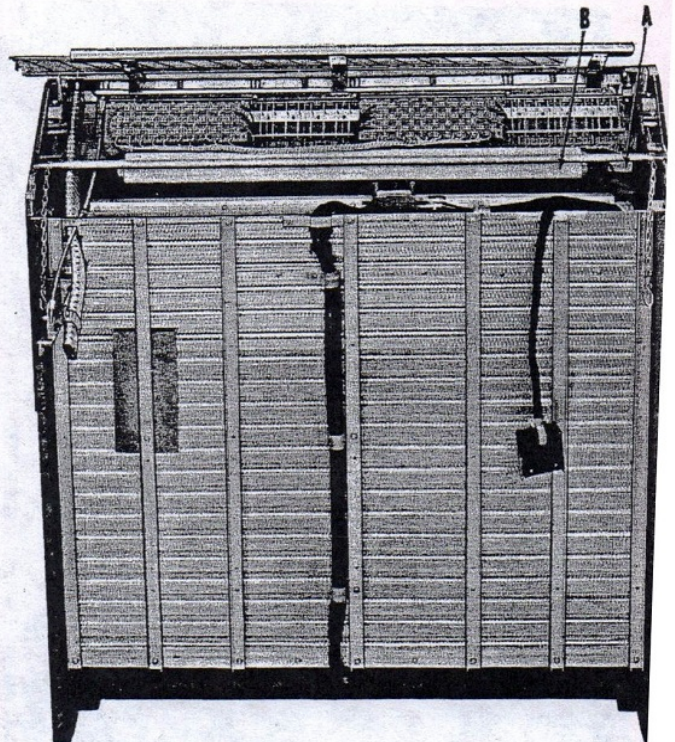

**FIG. 3—Inside View of Front Door**

## TO ADJUST ACCUMULATOR AND SLUG REJECTOR

Note: All Rock-ola Model 1452 phonographs are sent from the factory with the accumulator and slug rejector set to give one play for 5c, two plays for 10c and five plays for 25c.

### 1. FOR ONE PLAY FOR 5c, TWO PLAY FOR 10c AND SIX PLAYS FOR 25c OPERATION

- A. Insert thin blade of pocket knife under quarter wafer (A-Fig. 5), twist slightly, raising wafer pin (B-Fig. 5) from hole.
- B. Keep quarter wheel (G-Fig. 5) from rotating and move quarter wafer until pin drops into six play hole (C-Fig. 5) farthest from ratchet spring stud (F-Fig. 5)
- C. No wiring or slug rejector changes are necessary.
- D. Replace decal on dome glass with properly designated one.

### 2. FOR ONE PLAY 10c & THREE PLAYS FOR 25c OPERATION

- A. Same as 1A. above.
- B. Keep quarter wheel from rotating and move quarter wafer until wafer pin drops

into three play hole (H-Fig. 5) closest to ratchet spring stud (F-Fig. 5).

- C. Remove white-red tracer wire from 10c position on slug rejector terminal strip, and tape up to prevent shorting.
- D. Move white-black tracer wire from 5c position and fasten securely to 10c terminal.
- E. Set slug rejector to reject 5c coins by removing cover plate on slug rejector (E-Fig. 6). Loosen screw (D-Fig. 6) and insert 5c coin stop (C-Fig. 6) under head of screw (D-Fig. 6). Then tighten screw and replace cover plate.
- F. Replace decal on dome glass with properly designated one.

### 3. FOR ONE PLAY 10c & FOUR PLAYS FOR 25c OPERATION

- A. Same as 1A on previous column.
- B. Keep quarter wheel from rotating and move quarter wafer until pin drops into four play hole (E-Fig. 5). This is the second hole from spring stud (F-Fig. 5).
- C. Same as 2C above.
- D. Same as 2D above.
- E. Same as 2E above.
- F. Same as 2F above.

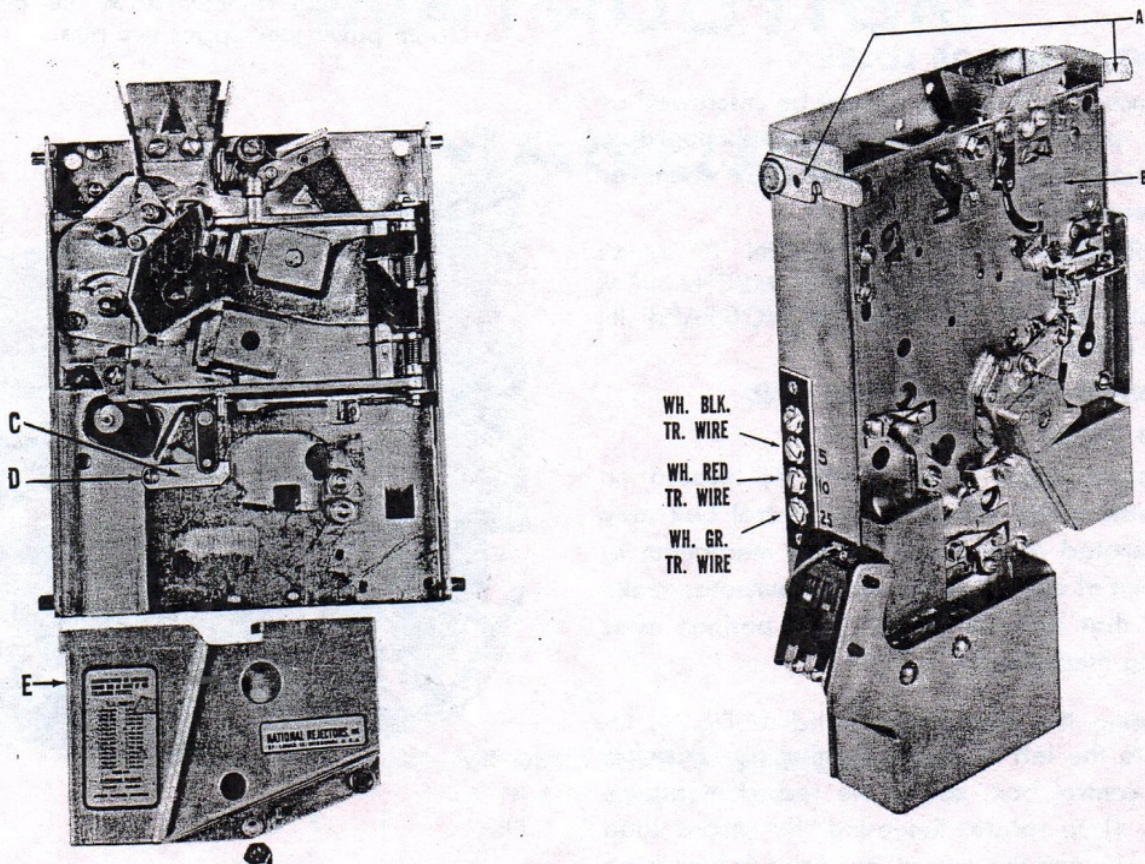
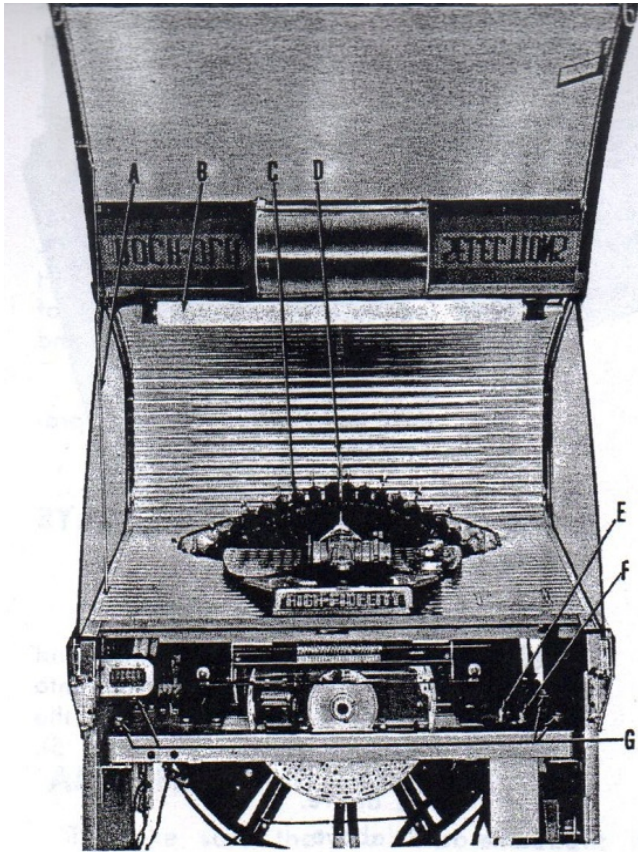

FIG. 6 SLUG REJECTOR



**FIG. 4—Inside View of Cabinet**

### MECHANISM ANCHOR LOCKS

Four anchor bolts (G-Fig. 4) must be unscrewed as far as possible before operating phonograph. These bolts must be tightened securely whenever the phonograph is transported.

**IMPORTANT:** REMOVE WOODEN PACKING BLOCKS FROM UNDERNEATH MECHANISM CHASSIS BEFORE SETTING PHONOGRAPH IN OPERATION.

### MECHANISM POWER SWITCH AND RECORD LOAD SWITCH

Mechanism power switch (F-Fig. 4) located on front side of the chassis in the control box may be operated at any time to stop mechanism at any point of operation. For service purposes, make certain that switch is left in "ON" position after servicing mechanism.

Depressing the record load switch (E-Fig. 4) located to the left of the mechanism power switch in the control box, causes the record magazine (C-Fig. 4) to rotate. Releasing the record load switch will stop the record magazine in any position to install or remove records.

1. Depress RECORD LOAD switch (E-Fig. 4) and hold down until record magazine rotates.
2. If record magazine does not rotate due to phonograph being in "Music play" position; place tone-arm in record cut-off groove and allow grip arm (D-Fig. 4) to return record to record magazine. The record magazine will then rotate.
3. After record magazine begins to rotate, move "Mechanism Power" switch (F-Fig. 4) to "OFF" position.
4. Release record load switch in position desired to stop record magazine to install records.
5. After records have been installed, reset mechanism power switch to "ON" position.

### TO REMOVE SLUG REJECTOR

1. Lift pawl (A-Fig. 6) on each side of slug rejector housing, pull top of slug rejector (B-Fig. 6) forward, lift up and forward to remove.
2. To replace, insert lower pivot pins of slug rejector into lower housing slots. Swing upper part of slug rejector back into position until both pawls lock upper two pins.

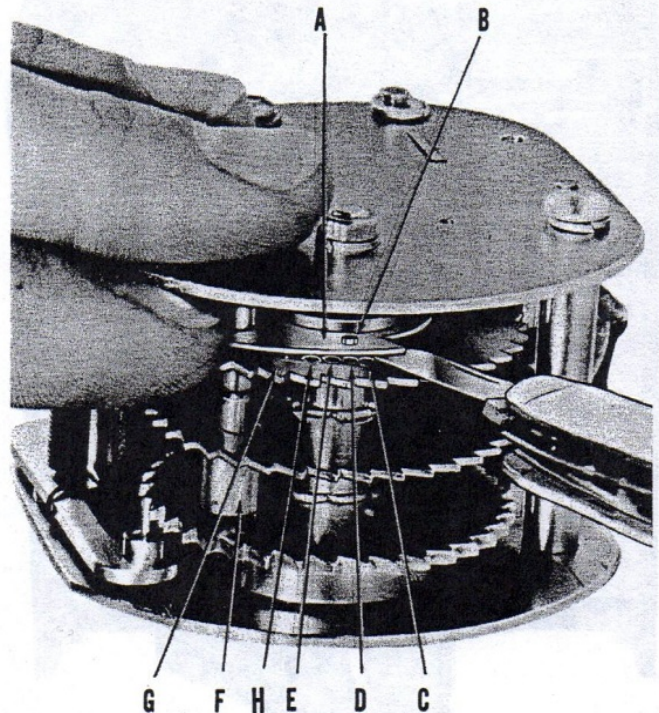

**FIG. 5—View of Accumulator**

## OPERATING INSTRUCTIONS

### MECHANISM CYCLE OF OPERATION

The mechanism cycle begins with the dropping of a coin in the phonograph which accumulates plays on the master ratchet wheel in the accumulator assembly.

When a selector button is pressed to make a selection, the corresponding selector coil in the selector coil bank assembly is momentarily energized, and a credit is removed from the master ratchet wheel in the accumulator assembly. The momentarily energized coil moves a selected lever to the outer edge or "play" position on the selector coil bank assembly.

This movement of any selection lever will close a circuit to the "Start" relay in the power distribution panel, which turns on the turntable motor, amplifier, and magazine motor. This motor revolves the record magazine and selector arm clockwise or counter-clockwise, depending on the position of the "magazine reversing switch". The selector arm rotates a carriage over the selection levers which radiate out of the selector unit assembly.

There are 120 levers, one for each record side, arranged in two parallel rows of 60 levers each. The levers for playing the even numbers are in the row toward the rear of the mechanism. The levers for playing the odd numbers are in the row towards the front. The selection sequence is such that even numbers are selected from 2 to 120, and odd numbers from 119 to 1.

Rotation of the magazine continues until a contact in the bottom of the carriage assembly strikes the selected lever in its path. This action closes a circuit to the "interlock relay trip coil", thereby repositioning its associated contacts. This short-circuits the magazine armature and dynamically brakes the motor causing the magazine to stop. In addition, a circuit is closed to the grip motor which revolves the cam shaft, and causes the jaws of the grip arm to grasp the record.

At this point the micro switch, located to the left of and adjacent to the grip mechanism housing, is operated by a cam. This disconnects the magazine motor armature.

As the grip motor continues to operate, the grip arm removes the record from the record magazine and proceeds to place it on the turntable. A mechanical action is involved in the gripper arm which determines proper turning or positioning for either odd or even selections.

As the record is being placed on the turntable, the outer micro switch lever falls into the groove of the cam. The micro switch closes a circuit to the proper "selector lever cancel solenoid" located on top of the carriage assembly, and causes the spring plunger to strike the selected lever, resetting it to its normal position. The solenoid continues to be energized until the grip cam, which is located at the right side of the grip housing, mechanically snaps a group of ganged switches called the "grip cam limit switches". These switches change position, opening the circuit to the energized solenoid, thus releasing the spring plunger. In addition, the grip motor circuit is interrupted and a circuit to the "interlock relay release coil" is completed. This releases the interlock relay to its original position, and places a short-circuit across the grip motor armature which causes it to stop.

During the above actions, the tone arm cam has placed the tone arm on the record, and the machine has reached the music cycle.

When the tone arm reaches the record cut-off groove, the tone arm switch closes the circuit to the "cancel relay coil". The cancel relay contacts close the grip motor circuit in such a manner that its direction of rotation is reversed and consequently the grip jaws engage the record and the arm returns the record to the magazine.

As the grip jaws begin to release the record, the inner micro switch is again operated, connecting a circuit to the magazine motor armature. After the grip jaws have released the record, the "grip cam limit switch" snaps to its original position and opens the cancel relay circuit. This in turn, disconnects power from the grip motor and short circuits it, causing the motor to stop. The relaxed contacts of the "grip cam switch" also close the muting circuit, and break the circuit to the "start relay" providing no additional selections are registered. As the "start relay" contacts open, the circuits to the turntable motor and amplifier are broken, causing them to be inoperative. This completes the mechanism cycle.

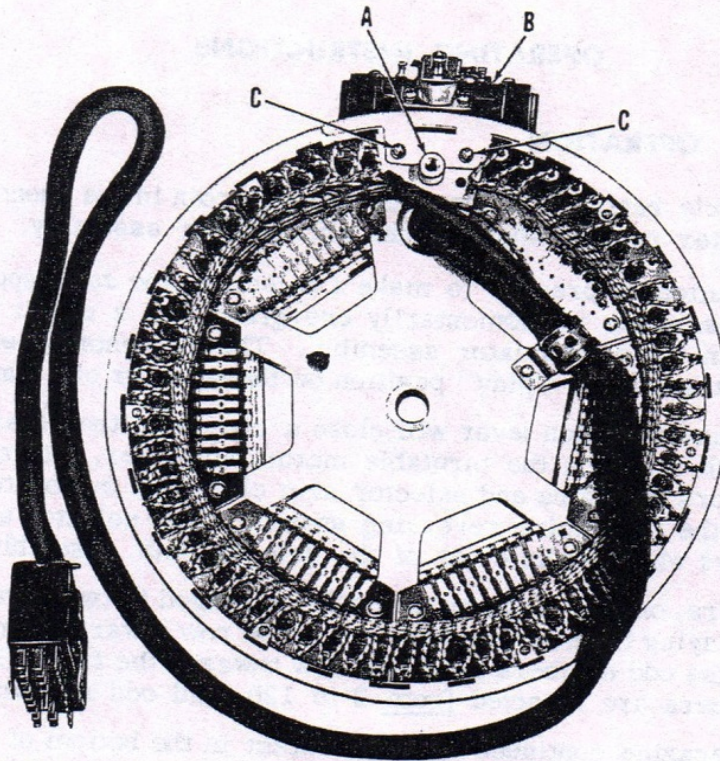

## REMOVAL OF SELECTOR UNIT

FIG. 1 SELECTOR UNIT

The selector unit is suspended in the mechanism by a shaft inserted through the center of the selector unit into a hollow shaft which supports the record magazine. The selector unit is positioned and kept from rotating by means of the shoulder bushing (A-Fig. 1) which is located at the upper right hand side behind the counter drive pulley.

The procedure for removing the selector unit is outlined below:

NOTE: Do not remove the counter drive pulley and drive cable when removing the selector unit. Allow the counter drive pulley to rest in the recessed opening under the counter pulley.

1. Move mechanism power switch to "OFF" position.
2. Depress the record load switch and rotate the record magazine so that the popularity counter carriage is positioned to the left side of the mechanism, and that the gripper arm is centered directly over the blank separator on the record magazine.
3. Take out 2 screws holding selector rail segment (C-Fig. 1) and slide out carriage assembly (B-Fig. 1). Do not remove cable wiring from carriage assembly.
4. Disengage selector cable from cable clamp under mechanism chassis plate, remove white-brown wire leading to speed connector, and disconnect the Jones plug at the end of the selector cable. Remove the retaining spring from the right side of the selector unit.
5. Loosen two square head set screws which fasten counter drive pulley to shaft at front of mechanism and two allen set screws on shaft at rear of mechanism. Remove the internal shaft from the front of the phonograph. Make certain that the counter drive pulley is not disengaged from the drive cable. Let the counter drive pulley rest in the recessed opening under the counter drive pulley.
6. Place hand under the selector unit for support, and remove hex nut on shoulder bushing (A-Fig. 1). Lower selector unit and remove. There is ample clearance between speaker baffle and mechanism chassis, for removal. To facilitate removal, it is advisable to remove the front door. Unfasten the two door chains. Pull out the front door cable through the rectangular opening in the speaker baffle, after disconnecting the 27 position Jones socket from the selector unit plug (or receiver unit), the 2 prong and 5 prong plugs from the power distribution panel and the 8 position socket from the accumulator unit.

To re-install selector unit, the reverse order of procedure should be used. Caution must be taken in setting the record counter to properly register the selection playing. Move the mechanism power switch to "ON" position. Select #2 record and allow gripper arm to place record on turntable. Before the two square head set screws in the counter drive pulley are tightened into the grooved portion of the shaft, manually turn the counter drive pulley (which is loose on the shaft) so that the counter carriage pawl is directly beneath and in the center of #1-2 record dial. Then tighten the two square head set screws in the counter drive pulley.

## DEMONTAGE COURONNE DE SELECTION ROCK-OLA 1454.....



1-Tout d'abord enlever le fil pilotant le système du compteur de popularité  
Puis, dévisser les deux vis à tête carrée pour libérer la poulie du compteur de popularité. Ensuite quand l'axe sera chassé, la poulie pourra alors être retirée

2-Mettre le chariot rotatif à 1 heure, puis, sur la couronne de sélection, dévisser les deux vis de la flasque permettant ensuite de sortir ce chariot rotatif (flasque située à 1 heure)  
Agir directement sur la molette du moteur du panier à disques pour ajuster la sortie du chariot



3-Sortir le chariot des glissières

4-A l'arrière du juke, dévisser les deux vis avec une clé à lèvre afin de libérer l'axe. Faire un repère pour faciliter le remontage

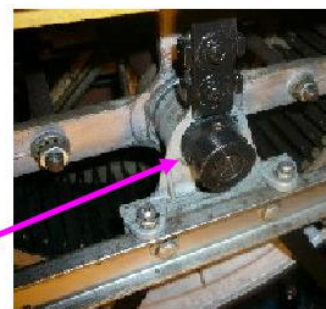

5-Enlever le ressort, puis dévisser la vis de positionnement de la couronne de sélection

6-Débrancher le fil de masse et le connecteur 27 points allant à la couronne  
Chasser l'axe de l'avant vers l'arrière jusqu'à ce que la couronne puisse descendre par le dessous

7-Quand la couronne est sur établi, enlever les 6 boulons traversant la couronne. Puis, dévisser les 2 vis de chaque module de 20 sélecteurs(soit 12 vis par flasque).





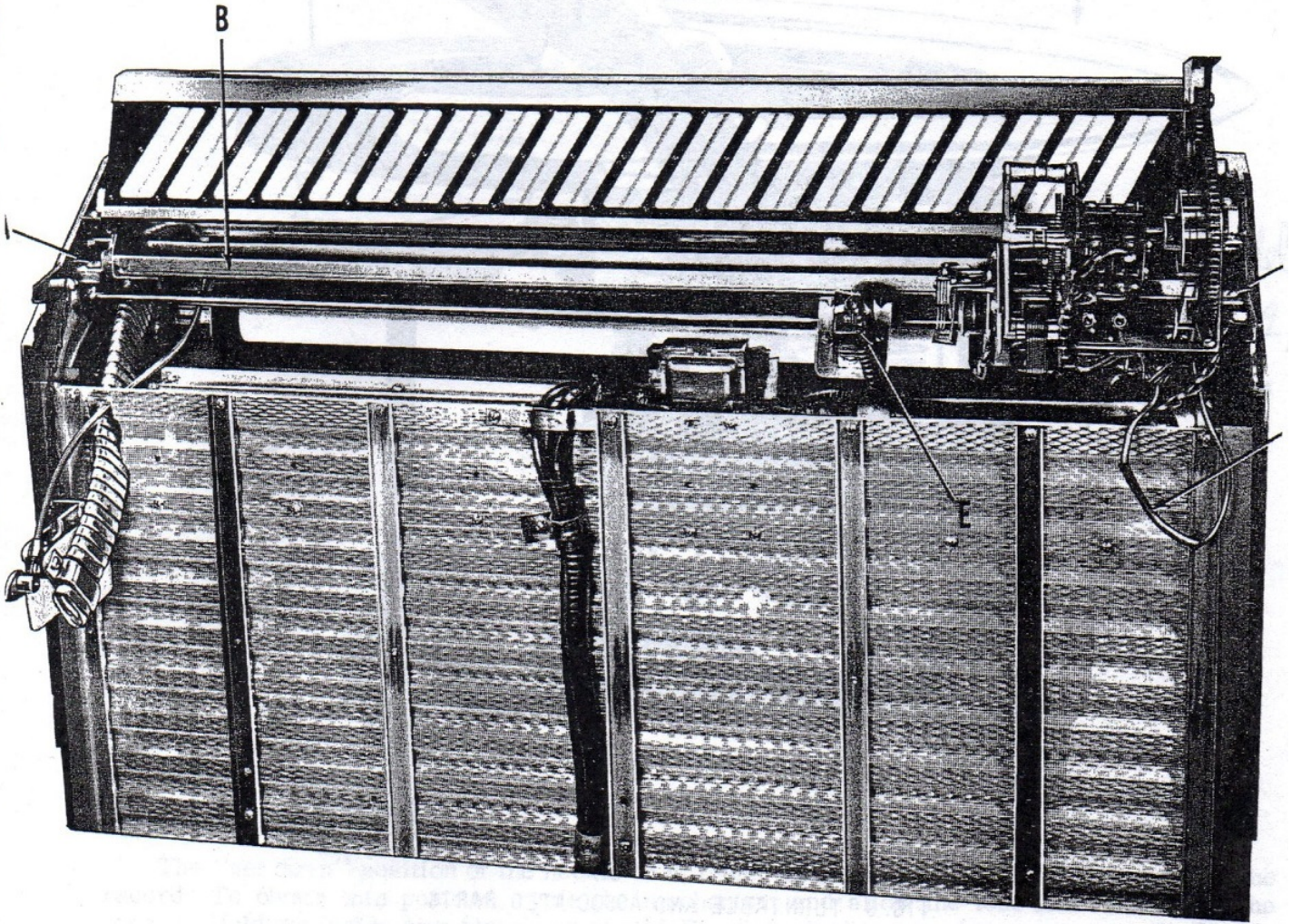

FIG. 2 PROGRAM HOLDER ASSEMBLY

### REMOVAL OF PROGRAM HOLDER ASSEMBLY

The program holder assembly (B-Fig. 2) may be removed for servicing by the following procedure:

1. Open the front door to the full extent of the two door chains.
2. Remove two machine screws (A-C-Fig. 2). Note that the brackets through which the screws are inserted, are elongated. This will permit the complete program holder assembly to be shifted laterally, so that it clears the two latch brackets on the cabinet, when the front door is closed.
3. Disconnect the "knife" connection at (D-Fig. 2). The connection is under the protective tubing.
4. Disconnect the 12 position Jones plug (E-Fig. 2).
5. Move the complete unit forward slightly to clear the two bosses on the side castings of the front door, and lift out.

After the program holder assembly has been removed, the selector switches are readily accessible for easy servicing.

NOTE: Detailed instructions on the operation of the Program Holder Assembly are to be found under heading "PROGRAM PANEL OPERATION".

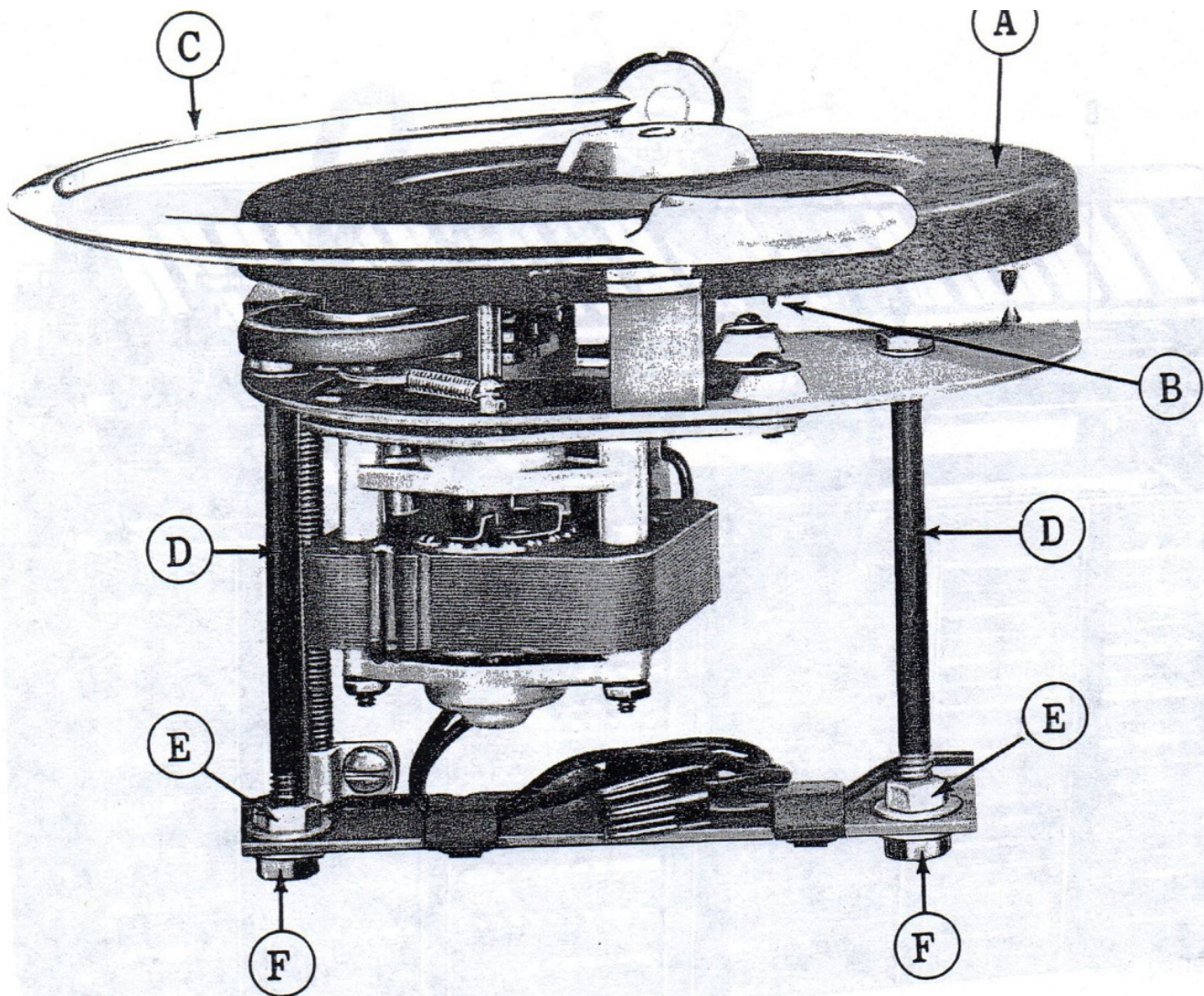

FIG. 3 TURNTABLE AND ASSOCIATED PARTS

### TURNTABLE HEIGHT AND CENTERING

The turntable (A-Fig. 3) must be level and in proper alignment with the center line of the inner and outer gripper arm castings. With the gripper arm (C-Fig. 3) in play position over the turntable, the top surface of the outer and inner gripper arms will be  $\frac{9}{32}$  inch above the playing surface of the turntable for a 7 inch record. The turntable mounting plate can be raised or lowered by loosening the lower lock nuts (F-Fig. 3) on the support studs (D-Fig. 3) and turning the upper adjustment nuts (E-Fig. 3) up or down to satisfy this condition. Shim washers can be inserted at (B-Fig. 3) between the gripper housing casting and the mounting plate to level the turntable with respect to the inner and outer gripper castings. The position of the gripper arm stop can be adjusted by bending the stop up or down.

To center a record over the turntable spindle, allow the gripper arm to lift a record from the record magazine. Before the record is placed on the turntable, move the mechanism power switch to "OFF" position. By rotating the gripper motor armature manually, lower the record to the turntable, and carefully observing the relationship of the turntable spindle to the center hole of the record. If adjustment is necessary, remove the turntable from the turntable motor by means of the screw in the centering locator.

After the turntable has been removed, two mounting screws and two hex nuts which fasten the turntable motor to the mounting plate are visible. Loosen the screws and hex nuts and shift the turntable plate in the direction necessary for perfect alignment. Then tighten the screws and nuts carefully so that the mounting plate does not shift out of position. When replacing the turntable, make certain that the rubber covered idler wheel is seated properly under the drive wheel of the turntable.

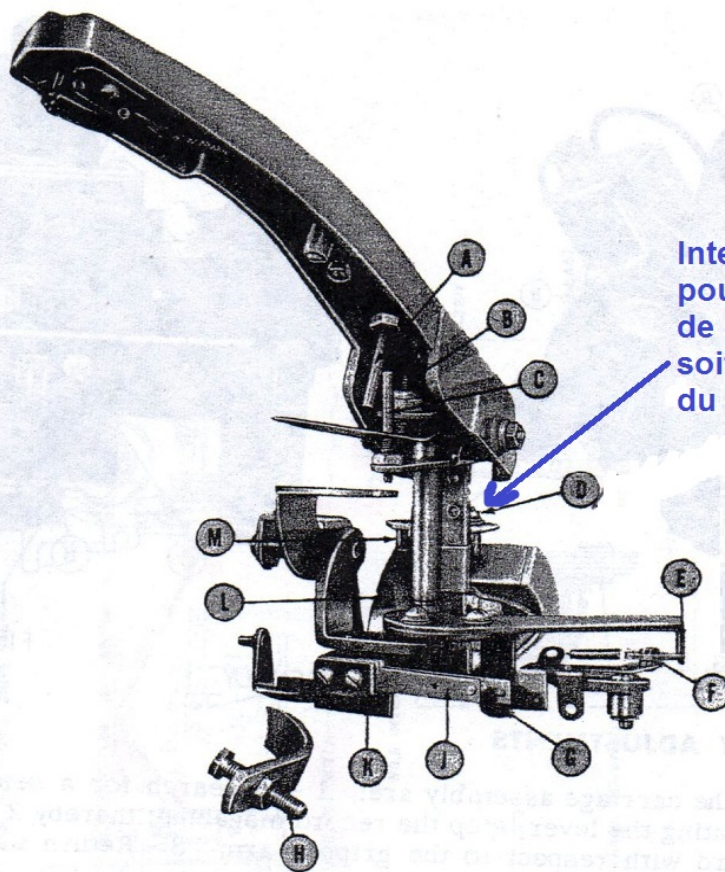

FIG. 4 TONE ARM ASSOCIATED PARTS

### TONE ARM ADJUSTMENTS

The "set down" position of the needle on a 7-inch record is  $\frac{3}{32}$  inch from the edge of the record. To obtain this position, cycle the mechanism and allow the tone arm to "set" on the record. Hold the inside cam plate stop pin (M-Fig. 4) against inside of tone arm cam (L-Fig. 4). Loosen screw at (D-Fig. 4) and move tone arm so that needle rests  $\frac{3}{32}$  inch from edge of record. Then carefully tighten screw (D-Fig. 4). *2,3 mm*

The record "cut-off position" is  $2\frac{1}{32}$  inches from the center of the record hole toward the outer edge of the record. The bracket at (G-Fig. 4) can be bent to actuate the tone arm switch (J-Fig. 4) when needle reaches the cut-off position. The trip dog (F-Fig. 4) is a safety device to prevent re-playing the same record by jarring the tone arm back across the record. The trip dog (F-Fig. 4) should release from bracket (E-Fig. 4) slightly before the needle reaches the record cut-off position. Bracket (K-Fig. 4) on which the tone arm switch is mounted can be bent to obtain this condition.

The needle pressure on the record is eight grams. When adjusting for needle pressure, turn adjusting screw (B-Fig. 4) accessible through the top of the tone arm, "clock-wise" to increase and "counter-clockwise" to reduce needle pressure. Needle pressure readings must be taken at the point of contact of the needle on the record.

The tone arm height must be adjusted so that the needle just touches the flocking on the turntable as the tone arm moves across it. Loosen nut which locks adjustment screw (C-Fig. 4). Turn screw "in" to increase height and "out" to decrease the height of the needle with respect to the flocking on the turntable.

There should be at least  $\frac{3}{16}$  inch to  $\frac{1}{4}$  inch clearance between the tone arm needle and the bow of the gripper arm as the tone arm passes over the gripper arm to "set down" position on the record. Adjustment screw (A-Fig. 4) can be turned "in" to decrease the clearance and "out" to increase the clearance between the gripper arm and the needle.

# Remplacement des têtes de lecture MONO par des STÉRÉO pour ROCK-OLA 1454, Tempo...

## 1/-Rock-Ola 1454 et Tempo 1 Mono:

Remplacement par une tête de lecture céramique universelle stéréo

Ex : Cellule Phanstiehl P-132D Stéréo

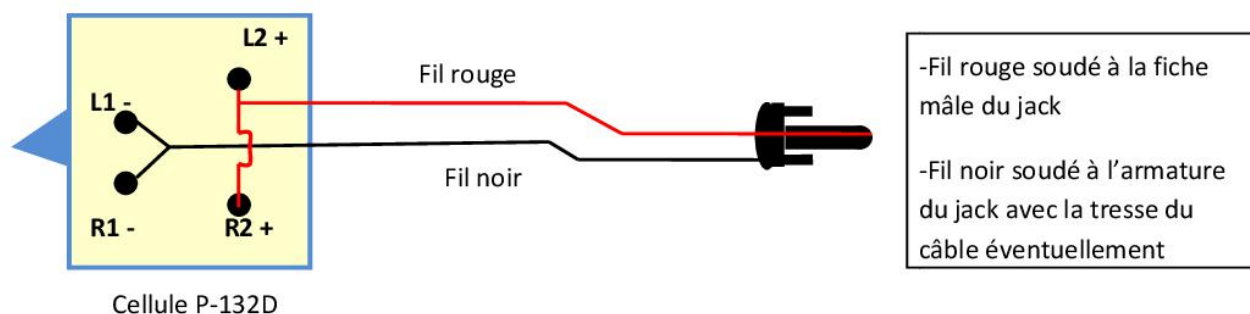

## 2/-Rock-Ola Tempo 2 Stéréo:

Remplacement par une tête de lecture céramique universelle stéréo

Ex : Cellule Phanstiehl P-132D Stéréo pour un ampli TEMPO stéréo en remplacement des cellules ELAC très utilisées en Allemagne

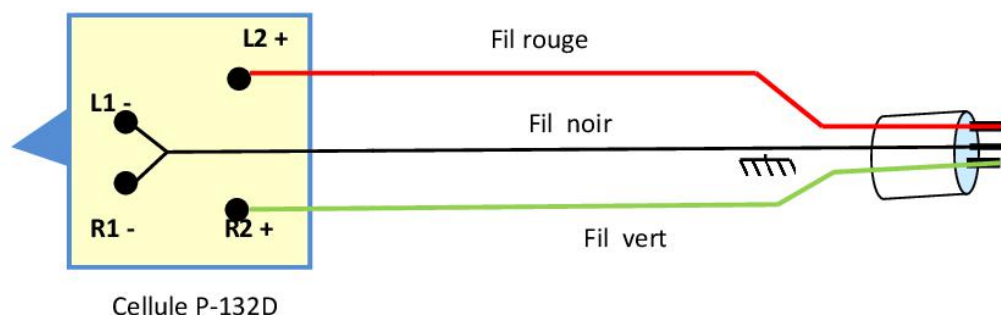

## Chariot tournant autour de la couronne de sélection

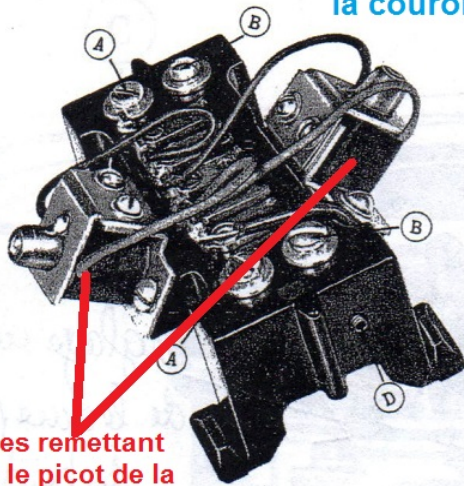

Bobines remettant à zéro le picot de la sélection choisie

FIG. 5

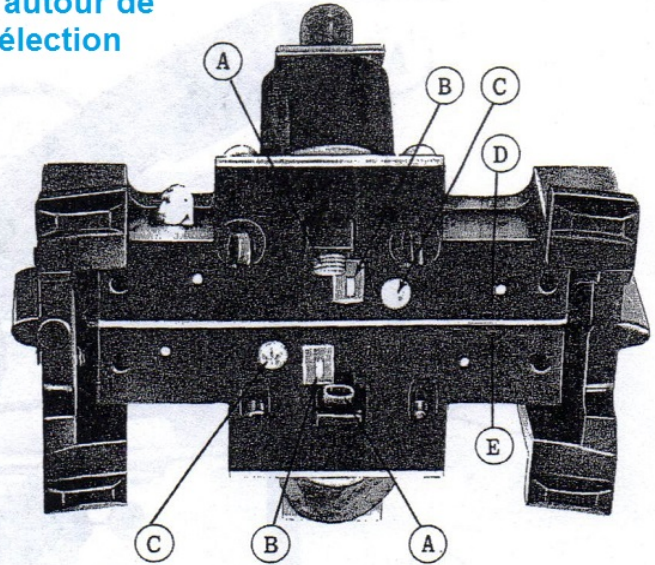

FIG. 6

### CARRIAGE ASSEMBLY

#### CARRIAGE ASSEMBLY ADJUSTMENTS

The functions of the carriage assembly are: 1 - to search for a selector lever in "play" position, and upon locating the lever, stop the record magazine; thereby 2 - Aligning or "indexing" the proper record with respect to the gripper arm. 3 - Return the selector lever from "play" position to normal position in the selector unit.

The carriage assembly is rotated over the selector unit by means of the selector arm, and held in position at each end by adjusting screws (H-Fig. 4). The rotation of the carriage is stopped when the proper contact (B-Fig. 6) in the carriage is grounded by a selector lever in "play" position. The respective cancel solenoid plungers (A-Fig. 6) operate whenever the "cancel relay follow switch" drops into the cam. The spacer pins (C-Fig. 6) merely serve to keep the selector levers in position by lightly pressing against them as the carriage assembly moves over the selector unit. The carriage contact blocks (D-Fig. 6) and (E-Fig. 6) can be individually adjusted so that the rotation of the record magazine can be stopped in proper relation to the inner gripper arm when either an "odd" or "even" numbered record is selected. The contact block mounting screws (A-B-Fig. 5) and the one allen head set screw (D-Fig. 5) which is used for "fine" adjustment, can be turned "in" or "out" depending on the direction necessary for adjustment. Only one allen adjustment screw (D-Fig. 5) is visible. Another allen adjustment screw for contact block (D-Fig. 6) is located at the diagonal corner, near mounting screw (A-Fig. 5). After adjustment, the two contact block mounting screws (A-B-Fig. 5) must be tightened.

To adjust the carriage assembly, select number "one" record, and before the inner gripper arm contacts the record, move the mechanism power switch to "OFF" position. Carefully observe the location of the record with respect to the center line of the inner gripper arm. The record should be aligned as closely as possible to the center line of the inner gripper arm. If the record is not in perfect alignment, loosen one adjustment screw (H-Fig. 4) depending on the direction in which the carriage must be moved. Move the carriage assembly to the adjustment screw, and then tighten the other adjustment screw up to the carriage to keep it from shifting laterally. Be sure to tighten the lock nuts after adjustment. Then check the record alignment with number "sixty-one" record. If the alignment is off, the carriage assembly can be again adjusted by means of the adjustment screws (H-Fig. 4) to compensate for the difference between number "one" and "sixty-one" record.

The record alignment with respect to the inner gripper arm must also be checked with the number "two" and "sixty" records. However, if adjustment is necessary, the contact block (E-Fig. 6) must be adjusted by loosening the mounting screw (B-Fig. 5) and moving the contact block by means of the allen head screw (D-Fig. 5) which is provided for this purpose.

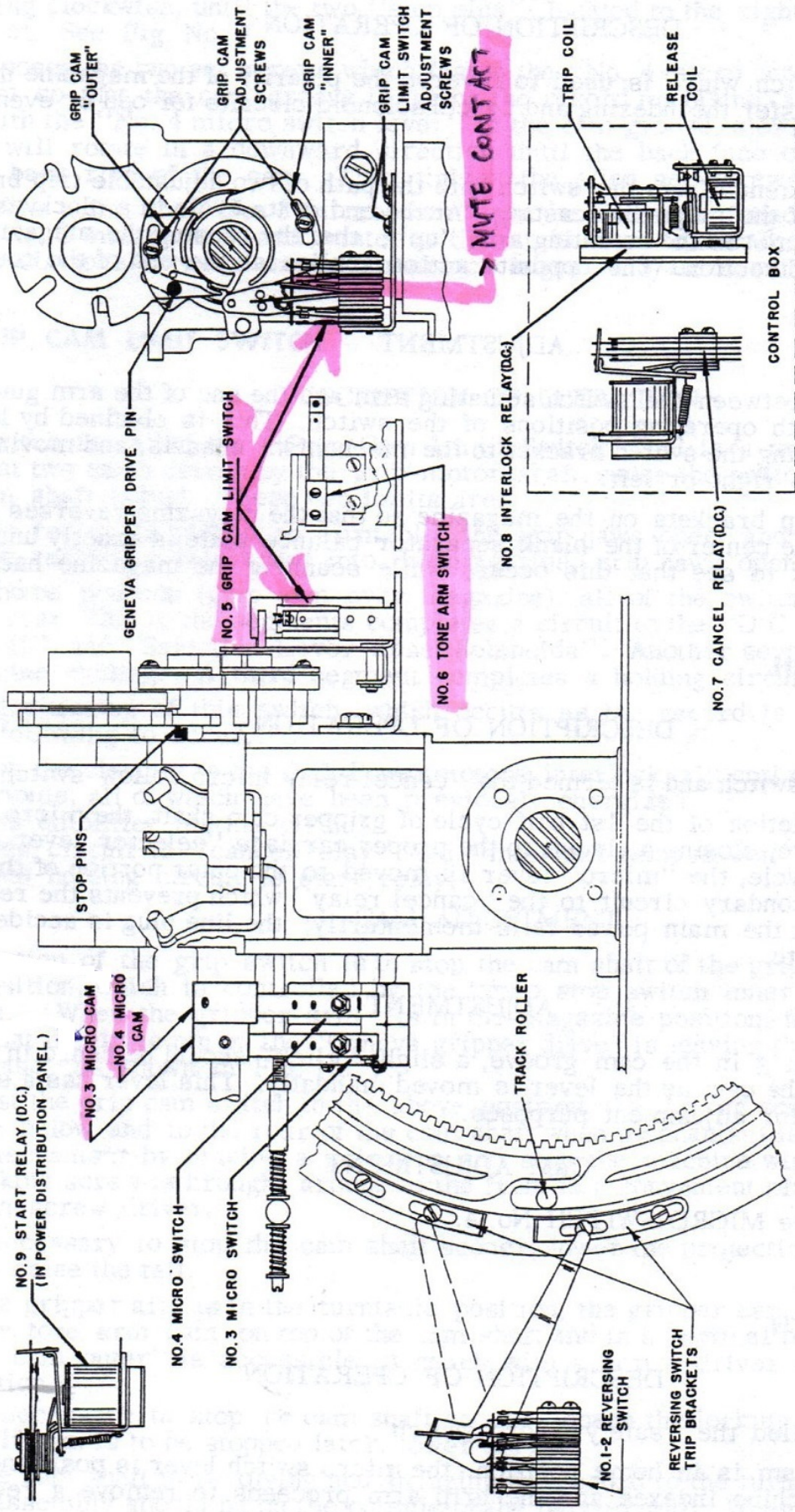

FIG. 7 PICTORIAL DIAGRAM OF MECHANISM AND ASSOCIATED PARTS

## **NO. 1-2 REVERSING SWITCH**

### **DESCRIPTION OF OPERATION**

This is a 4 PDT switch which is used to reverse the polarity of the magazine motor armature current, and to transfer the indexing and cancel solenoid circuits for odd or even selections. (See Diagram)

An actuating arm extends from the switch into the path of two adjustable trip brackets protruding from the front of the magazine casting. At the end of its cycle in a clockwise direction, one of the trip brackets moves the actuating arm "up"; thereby causing the magazine to rotate in a counter-clockwise direction. The opposite action applies at the end of the counter-clockwise rotation.

### **ADJUSTMENT**

1. The clearance between the switch actuating arm and the end of the arm guide slot shall be equal for both operating positions of the switch. This is obtained by loosening the two screws holding the switch bracket to the mechanism chassis, and moving the switch assembly to the right or left.
2. Adjust the 2 trip brackets on the magazine so that the magazine reverses its direction of rotation as the center of the blank separator balance plate is exactly under the gripper arm. Check to see that this occurs while scanning the magazine back and forth.

## **NO. 3 MICRO SWITCH**

### **DESCRIPTION OF OPERATION**

This is a "SPDT" switch and is termed the "cancel relay micro follow switch".

Prior to the completion of the 1st half cycle of gripper cam shaft, the micro switch lever falls into the cam groove, closing a circuit to the proper carriage "selector lever cancel solenoid". On the return cycle, the "micro" lever is moved to the outer portion of the cam. This action completes a secondary circuit to the "cancel relay" which prevents the relay from unlocking in the event that the main power fails momentarily; the line plug is accidentally pulled from the wall outlet; etc.

### **ADJUSTMENT**

When the lever rests in the cam groove, a slight "click" should be heard in the center of the drop off portion of the cam as the lever is moved manually. This lever has a set screw and lock nut arrangement for adjustment purposes.

### **CAM ADJUSTMENT**

For adjustment see MICRO SWITCH No. 4.

## **NO. 4 MICRO SWITCH**

### **DESCRIPTION OF OPERATION**

This switch is called the "safety micro switch".

When the mechanism is in home position, the micro switch lever is positioned in the cam groove. After the machine indexes and the grip arm proceeds to remove a record from the magazine, the switch disconnects the magazine motor armature.

### **ADJUSTMENT**

Same as Switch No. 3.

## CAM ADJUSTMENT

Move the "service switch" on the control box to "OFF" position.

Manually, rotate the cam shaft by turning the knurled knob which extends from the grip motor housing clockwise, until the two "stop pins", located to the right and adjacent to the grip housing, meet. See Fig. No. 7.

Then, loosen the two set screws which fasten the "No. 4 micro cam" to the cam shaft. Rotate the cam so that the cam groove is facing the record magazine, and is flush to the gripper housing. With the "No. 4 micro switch lever" in the cam groove, slowly move the cam so that the groove will rotate in a downward direction until the back face of the micro switch lever strikes the back rise of the cam. Then tighten the allen set screws.

From this point, the "No. 3 micro cam" can be adjusted if necessary. Loosen the set screws in "No. 3 micro cam" and rotate, so that it is flush to the adjacent "No. 4 micro cam" and the gap distance between the two interlock edges is 3/16 of an inch.

### NO. 5 GRIP CAM LIMIT SWITCH

#### DESCRIPTION OF OPERATION

This switch is called the "Grip Cam Limit Switch" and is a multi-pole snap-switch so arranged that two cams driven by the grip motor shaft cause the switch to snap at the limits of the grip cam shaft travel. These two limits are:

1. When record is placed on turntable, the grip jaws open; and
2. When record is reinserted into the magazine, grip jaws open.

In the home position (grip arm over magazine), all of the switch actuating contacts are made to the rear. One of the segments completes a circuit to the "D.C. Power Motors," "Interlock Trip Coil", and "Selection Lever Reset Solenoids". Another segment mutes the amplifier during machine cycling. A third segment completes a holding circuit to the "Start Relay".

The repositioning of this switch, which occurs as the record is placed on the turntable causes the following to occur.

1. Opens the circuits to the D.C. Power motors, interlock trip coil and selection lever reset solenoids, all of which have been previously energized.
2. Opens amplifier muting circuit.
3. Closes circuit to "cancel relay" and "interlock release coil".
4. Closes holding circuit to start relay.

#### CAM ADJUSTMENT

The function of the grip switch is to stop the cam shaft of the gripper in the magazine and turntable position, which is controlled by the "grip stop switch inner" and "grip stop switch outer" cams. When the gripper arm is in the magazine position, the cam shaft should be stopped so that the drive pin on the "Geneva gripper drive" is leaving the groove of the "Geneva gripper release" as shown in Fig. No. 7.

To adjust the grip cam switch in the above position, the locking screw of the "grip cam inner" will be below and to the rear of the cam shaft when mechanism is in the standby position. Cycle the mechanism by making a selection and stop the machine with the mechanism switch when the locking screw is brought around to the front in a convenient place to loosen the locking screw with a screw driver.

If it is necessary to stop the cam shaft sooner, lower the projecting tail of the cam, and to stop it later, raise the tail.

When the gripper arm is in the turntable position, the gripper cam should stop with the flange portion of the tone arm cam on top of the cam shaft and in a vertical plane. The locking screw of the "grip cam outer" is accessible to reach with a screw driver in either the standby or playing position.

If it is necessary to stop the cam shaft sooner, loosen the locking screw and raise the tail of the cam. If cam is to be stopped later, lower the tail.

When the cam shaft is revolving and bringing the record to the turntable, the cam pin of the grip switch assembly should be on the outside of the barrier wall. When the grip arm is returning the record to the magazine, the cam pin should be in the inside of barrier wall.

The grip cam switch assembly is adjustable "in" and "out" and can be moved in this manner by loosening the two screws fastening the switch bracket to the mounting plate. Grip cam switch unit should be located so that the cam pin will be set so that there will be an equal clearance between the barrier walls at the point where they overlap when the cam pin is in the inner and outer position.



## **NO. 6 TONE ARM SWITCH**

### **DESCRIPTION OF OPERATION**

When the tone arm has reached the record cut-off groove, the tone arm switch is actuated completing the circuit to the grip motor through the cancel relay contacts.

### **ADJUSTMENT**

With the needle in "set down" position on the record (3/32 inch from edge of record) adjustment bracket (G - Fig. 4) should just touch the fibre stud on the back of the tone arm switch (J - Fig. 4). Air gap between switch contacts should be about .020. When tone arm needle reaches "cut-off" position (2 1/32 inches from center of record) trip dog (F - Fig. 4) should release slightly before tone arm switch contacts (J - Fig. 4) make.

## **NO. 7 CANCEL RELAY (DIRECT CURRENT)**

### **DESCRIPTION OF OPERATION**

This relay which is in the control box has two SPDT and two SPST contacts. In the relaxed position, this relay closes circuits to the grip motor, causing the grip arm to position a record on the turntable. When energized by the tone arm micro, the two SPDT contacts reverse the circuit to the grip motor armature and return the record to the magazine. One SPST contact is used to mute the speaker and the other serves as a locking contact for the coil. NOTE: This is a D.C. relay, and is not interchangeable with Models 1436 and 1436-A.

## **NO. 8 INTERLOCK RELAY (DIRECT CURRENT)**

### **DESCRIPTION OF OPERATION**

This relay, also located in the control box, is a mechanically latching type and has two coils which are termed the "Trip" and "Release" coils. The "Trip" armature has two single throw contacts, and the release armature has two sets of double-throw contacts which are connected in parallel to insure proper operation of the machine, should one set become dirty or fail to function.

In the normal position, (Prior to Indexing), the trip armature is relaxed and the release armature is mechanically latched down by an arm extending from the trip armature; with neither coil being energized. In this position, the two contacts on the trip armature are open and the forward contacts on the release armature are closed and condition the power motor circuits. The action of the device is as follows:

1. Carriage Indexing contacts strike a registered selector key and momentarily energize the interlock trip coil.
2. Trip armature operates, closing its two contacts which provide holding circuits to the Start relay and trip coil.
3. As the trip armature completes its stroke, the release armature relaxes, thereby re-positioning its contacts and mechanically latching down the trip armature. The release armature contacts short-circuit the magazine motor armature and apply power to the grip motor. This action results in the grip arm removing the record from the magazine and placing it on the turntable.
4. The device remains in this position until the "grip cam limit switch" operates, at which time the release coil is energized.
5. The release armature operates, placing its contacts in the forward position. This short circuits the grip motor, causing it to stop.
6. After the release armature completes its stroke the trip armature relaxes, mechanically latching down the release armature, and opening its two contacts.

NOTE: This is a D.C. relay and is not interchangeable with Models 1436 and 1436-A.

## **NO. 9 STARTING RELAY (DIRECT CURRENT)**

### **DESCRIPTION OF OPERATION**

This relay is located in the Power Distribution Panel and is called the "start relay". This relay is composed of two contacts. When the coil is energized by a selection, one contact will close the circuit to the turntable motor and the primary windings of the amplifier transformer. The second contact operates the magazine motor.

NOTE: This is a D.C. relay and is not interchangeable with Models 1436 and 1436-A.

## PROGRAM PANEL OPERATION

The program panel is composed of three separate panels, with forty selections on each panel. Rotation is effected by means of the program change motor, located on the left side of the unit. As the program change button is depressed, a circuit is completed to the motor, causing the program panel to rotate one hundred and twenty degrees. The degree of rotation is determined by the three groove cam, on which is positioned a five blade switch. Three of the five blades control the starting and stopping of the program motor, by means of the program change switch and the program relay. The additional two blades complete the circuit to the 300 MFD. section of the accumulator capacitor.

When the program panel exposes selections #1 to #40, the top micro switch lever is in the cam groove, and the lower switch lever is on top of the cam. In this position, the inner micro switch (closest to the mounting plate) of the top group of micro switches, completes a circuit to the commoning relay in the selector unit, which controls selections #1 to #20. The outer micro switch completes the circuit to the commoning relay which controls selections #21 to #40.

With selections #41 to #80 exposed on the program panel, the upper micro switch lever is on top of the cam and the lower micro switch lever is in the cam groove. In this position, the inner micro switch (closest to the mounting plate) of the lower group of micro switches completes a circuit to the commoning relay which controls selections #41 to #60. The outer micro switch completes the circuit to the commoning relay which controls selections #61 to #80.

When the program panel exposes selections #81 to #120, the upper and lower micro switch levers are on top of the cam. In this position, the inner micro switch (closest to the mounting plate) of the lower group of micro switches, completes a circuit to the commoning relay which controls selections #81 to #100. The outer micro switch completes the circuit to the commoning relay which controls selections #101 to #120.

## ACCUMULATOR ASSEMBLY

The accumulator mechanism is designed to accumulate a maximum of twenty-six credits. After a deposited coin strikes one of the levers of the coin switch which is located below the slug rejector, the D.C. circuit is closed to a corresponding coil accumulator electro-magnet (B-Fig. 9). As the electro-magnet is energized, the armature ratchet detent (A-Fig. 9) and the ratchet escapement armature assembly (C-Fig. 9) are drawn to the pole-piece of the electro-magnet. The armature ratchet detent locks the ratchet and hub assembly, and releases the escapement armature stud, permitting the 5¢ ratchet and hub assembly (F-Fig. 8) to accumulate the correct number of credits.

The 5¢ ratchet (F-Fig. 8) is located nearest the base plate, the 10¢ ratchet (E-Fig. 8) is in the center, and the 25¢ ratchet (D-Fig. 8) is nearest the top frame plate. The stud which is riveted to the 5¢ ratchet extends through the 10¢ and 25¢ ratchet discs. When the 10¢ and 25¢ electro-magnets are energized, they are released in the same manner as the 5¢ ratchet. The stud which is riveted to the 5¢ ratchet, permits it to rotate two, or five teeth, depending on the denomination of the deposited coin.

As the 5¢ ratchet rotates, the stud which was holding the control switch (B-Fig. 8) open, is rotated away from the control switch, and allows it to close. The top blades complete the circuit from the D.C. supply, through the reset contacts of the front door selection switches, to the 300 MFD. section of the electrolytic capacitor (A-Fig. 8). This charge on the electrolytic capacitor is dissipated in energizing the reset coil (J-Fig. 8) when a selector button is pressed. The gram pressure of the two top blades of the control switch is 35 to 40 grams, and the air gap is .015. The circuit to the "Select" light is completed when the two lower blades of the control switch close. The gram pressure of these blades is 10 to 15 grams, with a visible air gap between the blades.

When the reset coil (J-Fig. 8) is energized, the reset armature is pulled against the pole-piece of the reset coil. The reset pawl (G-Fig. 8) engages the 5¢ ratchet (F-Fig. 8) and moves the 5¢ ratchet back one tooth. The reset coil assembly (J-Fig. 8) must be adjusted, so that the reset pawl engages the 5¢ ratchet tooth approximately one-half of the tooth depth, and the stud on the ratchet escapement armature (C-Fig. 8) has about one-third of one tooth length overtravel.

As the reset coil armature moves against the pole-piece of the coil, it closes the selection impulse switch (H-Fig. 8). In closing, the left section of the switch should close slightly before the right section of the switch. The circuit through the left section of the switch is completed through the front door selection switches to a particular commoning relay coil in the selector unit assembly. The right section of the switch completes the circuit through the front door selection switches to a particular selector coil also in the selector unit assembly, corresponding to the selection made. The gram pressure of both sections of the selection impulse switch is 35 to 40 grams, with an air gap of .015. At the same time, the reset pawl (G-Fig. 8) moves the 5¢ ratchet back one tooth, and cancels one credit. When the last credit is cancelled the stud which is riveted to the 5¢ ratchet opens both sections of the control switch (B-Fig. 8) and breaks the circuit to the front door selection switches, the selector unit assembly and the "Select" light.

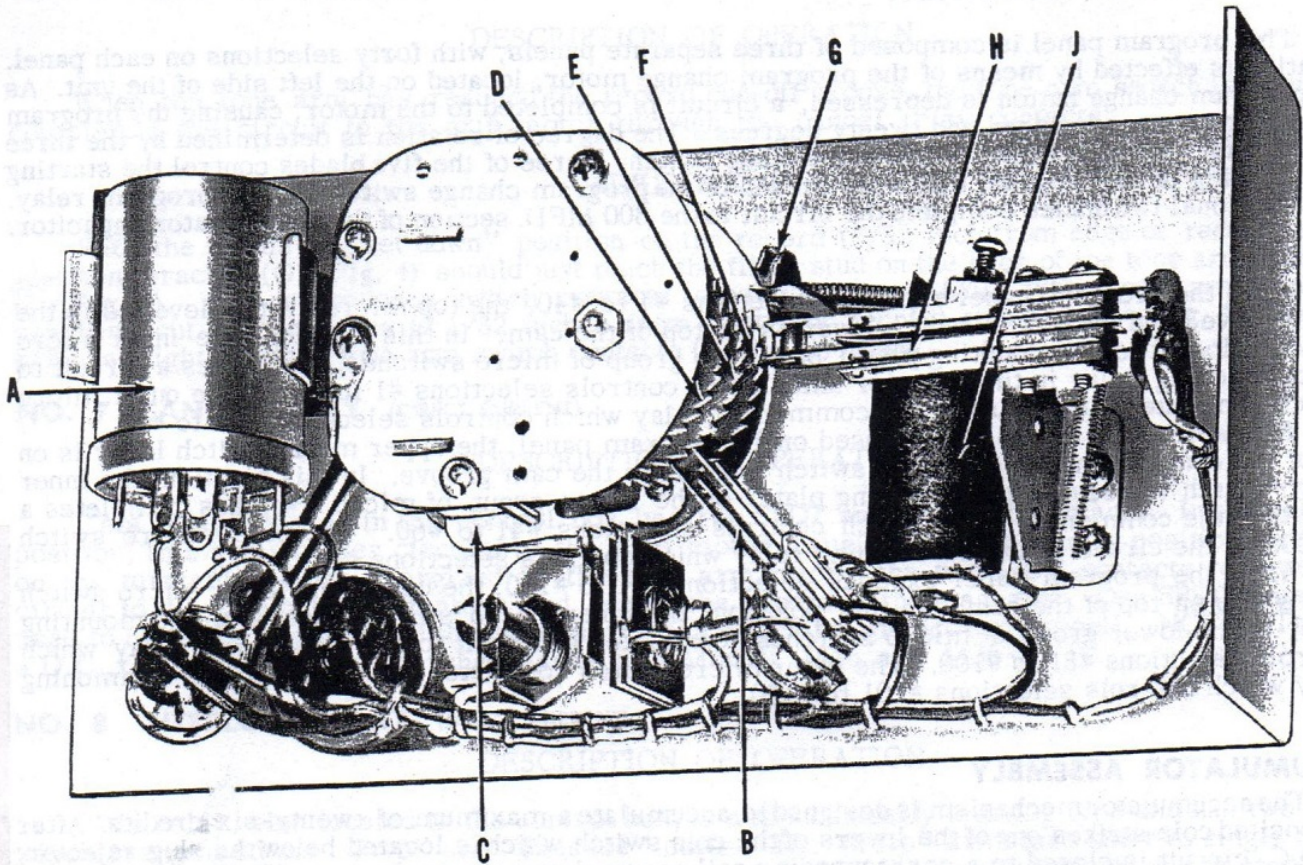

FIG. 8

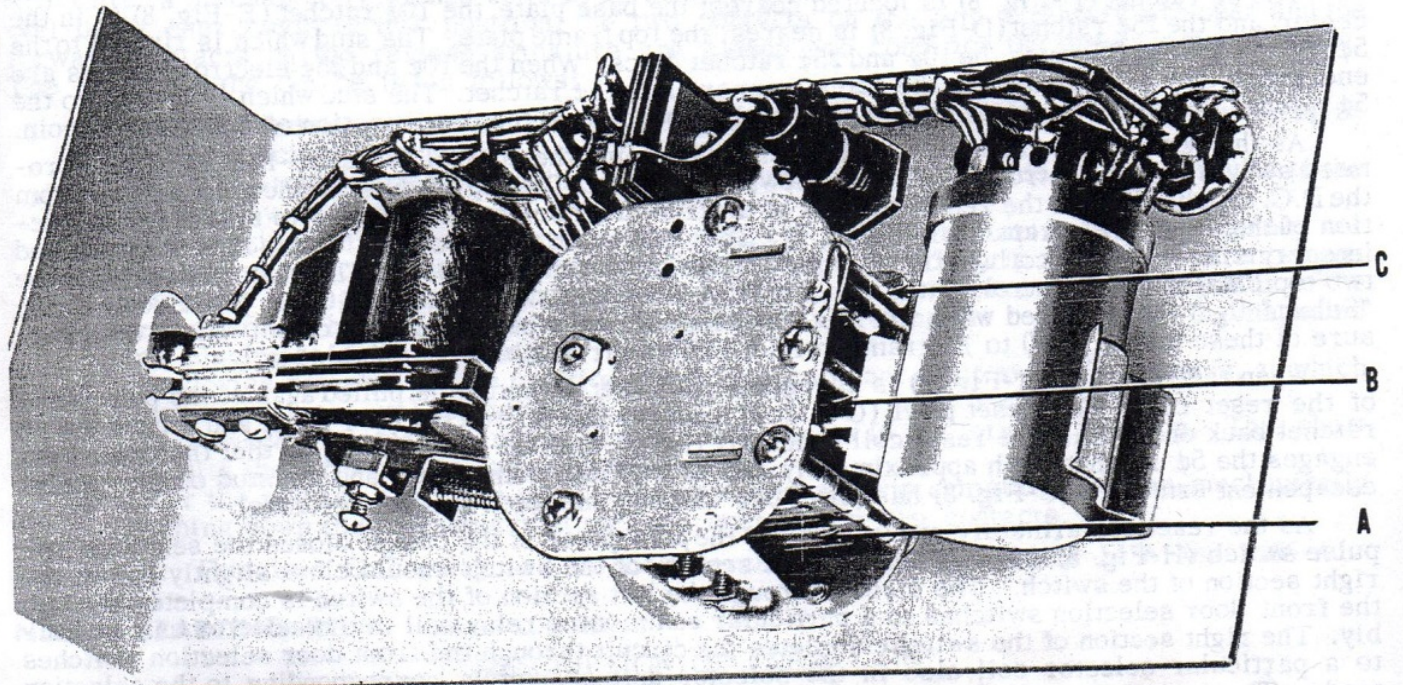
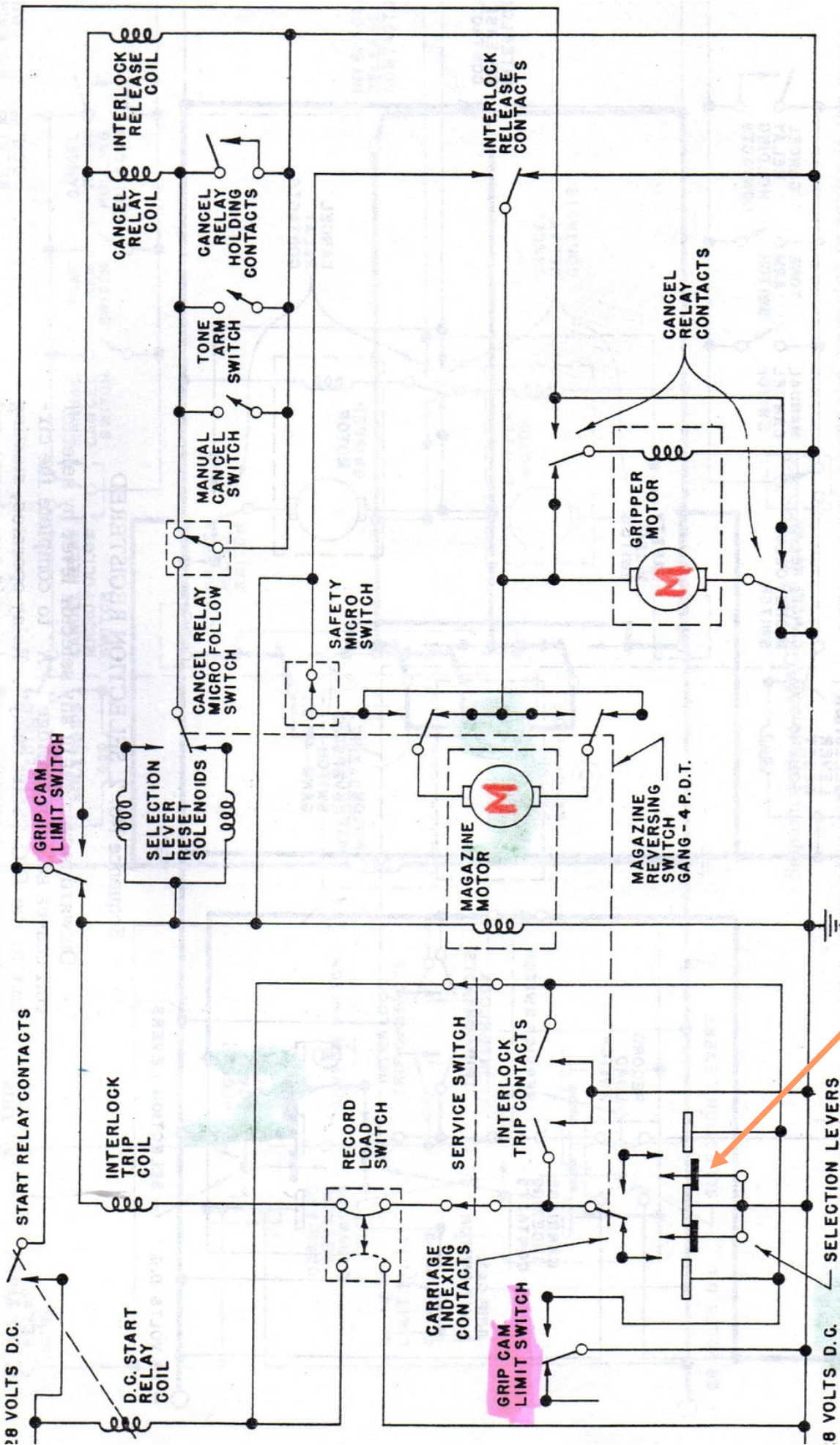

FIG. 9

ACCUMULATOR ASSEMBLY

**Séquences de sélection de la prise de disque : en traits gras les circuits activés**



Jukebox sous tension avec une sélection enregistrée, donc un des picots de la couronne s'est déplacée du centre vers l'extérieur

Sequence No. 1  
Power On - No Selections Registered.

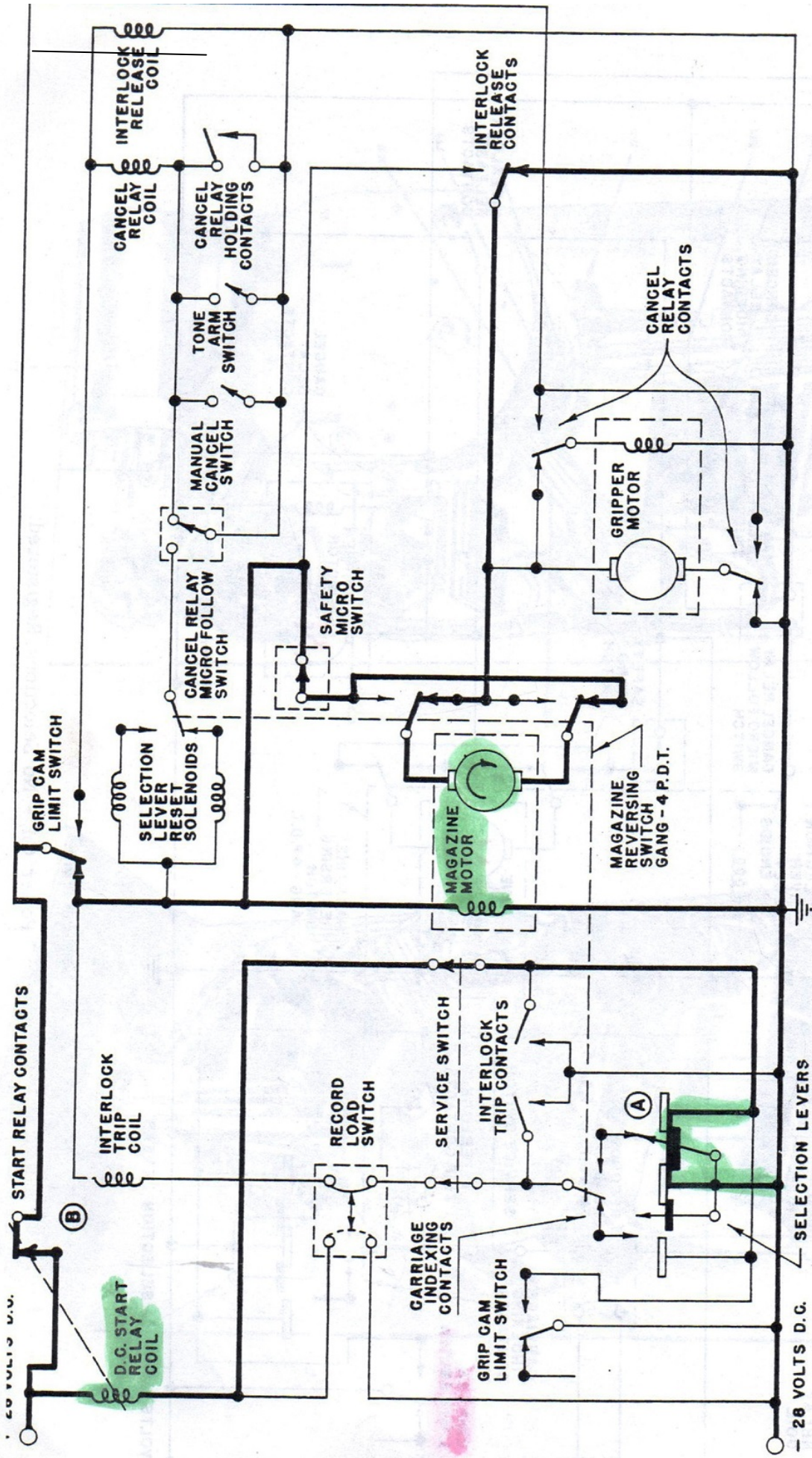

Sequence No. 2 SELECTION REGISTERED

Outward movement of any selector lever by selector coil causes selector "bridge" "A" to complete the circuit to the D C "Start relay". Relay operates, starting amplifier and turntable motor (circuit not shown) and contact "B" closes circuit to magazine motor. Magazine begins to rotate.

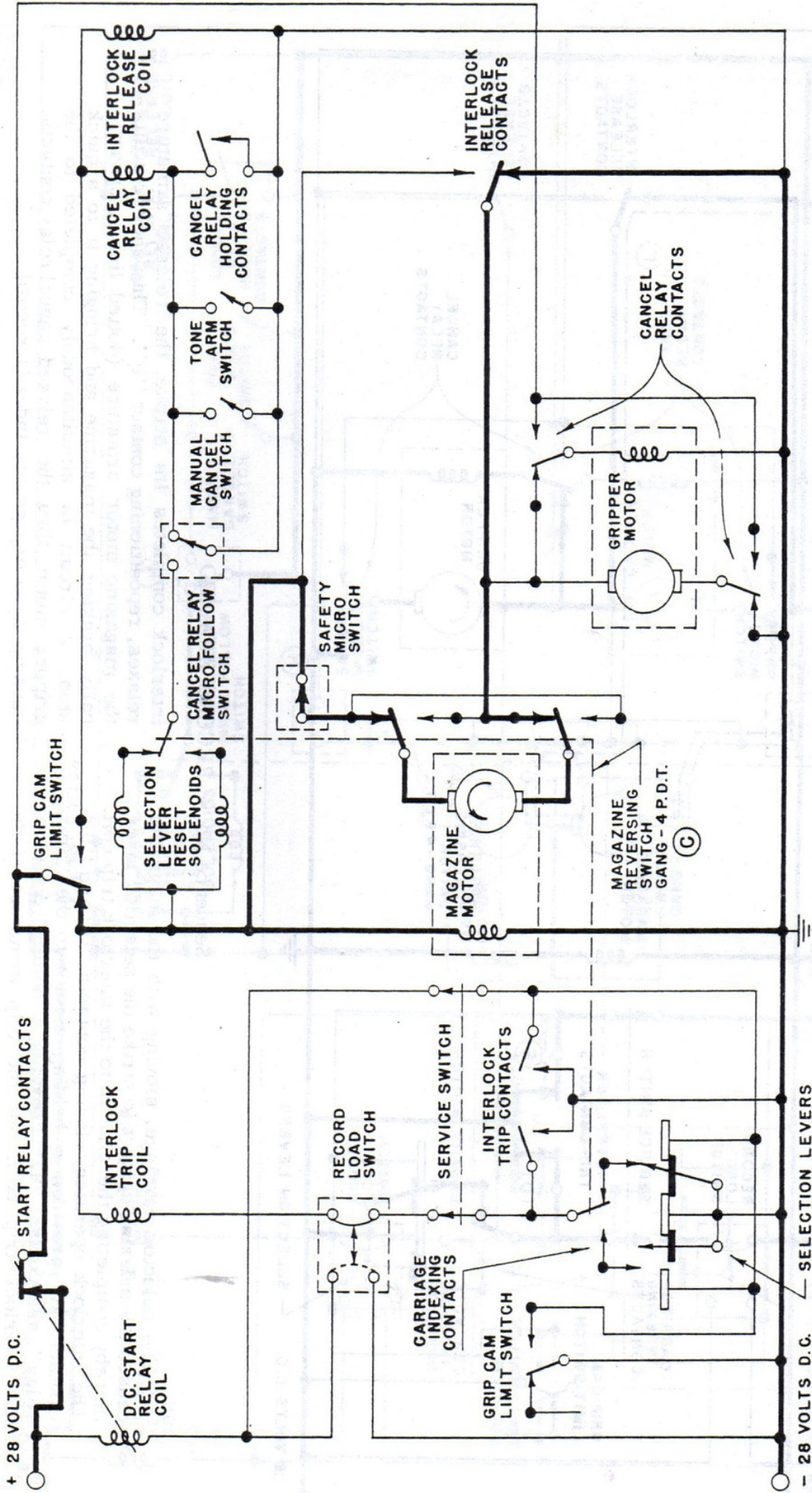

Sequence No. 3 MAGAZINE REVERSES

Depending upon the previous stopped position and the particular selection now registered, it may be necessary for the magazine to reverse its direction of rotation. This occurs when the magazine "trip brackets" operate the reversing switch "C". This reverses the direction of the current through the magazine motor

armature and causes the magazine to rotate in the opposite direction. Additional contacts on the reversing switch automatically connect the proper indexing contact and selection lever cancel solenoid for odd or even selections, depending on the direction of rotation of the magazine. (Dotted lines indicate the 4 reversing switch sections).

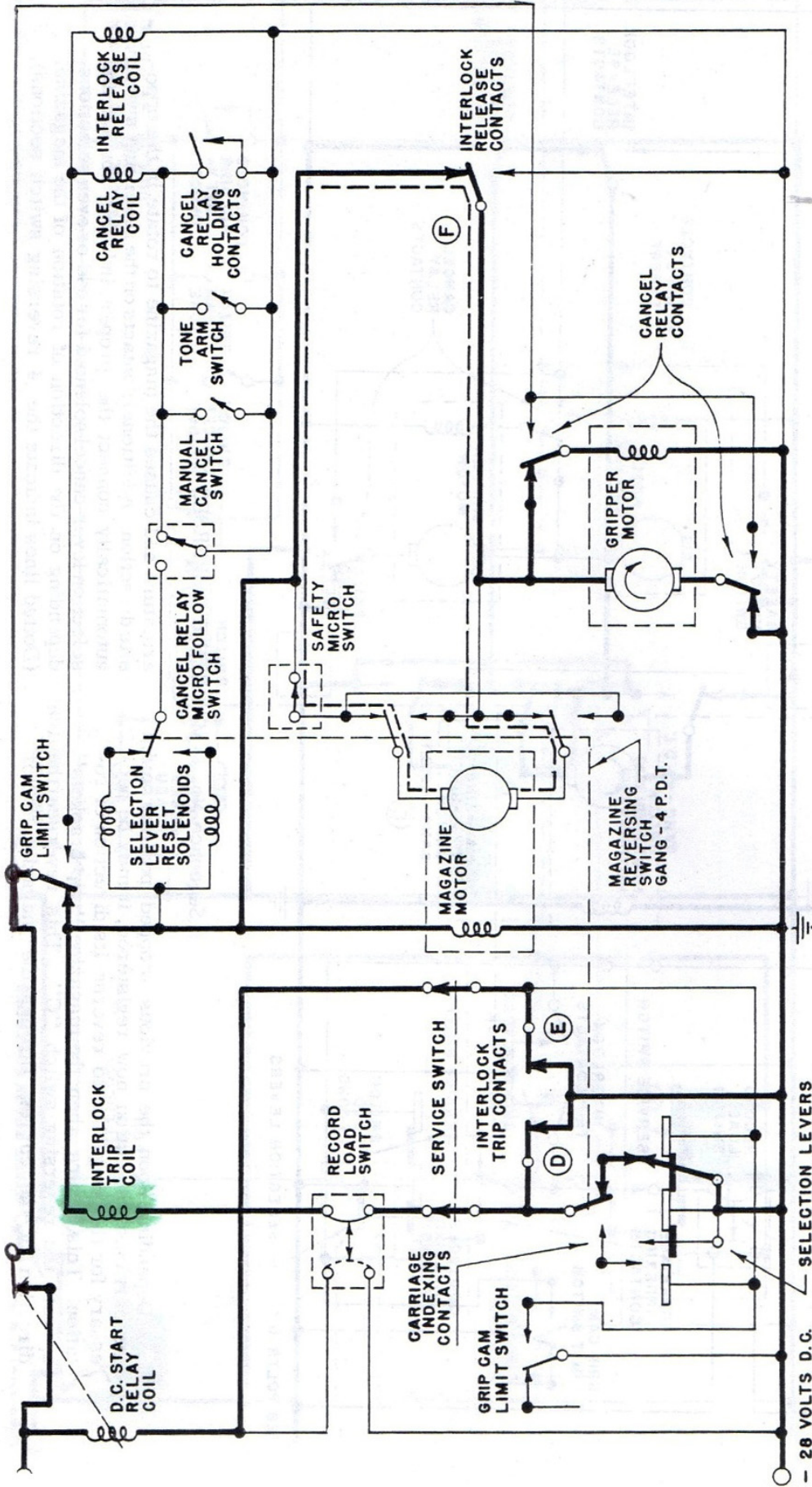

Sequence No. 4 RECORD INDEXED

The selector carriage, moving with the magazine, causes the indexing contact to strike the selection lever, thereby completing the circuit to the interlock lever. The interlock operates, closing contacts "D" and "E". Contact "E" provides a holding circuit to the "Start relay", and contact "D" provides a holding circuit to the interlock trip coil. As the trip armature of the

interlock completes its stroke, the release armature relaxes, repositioning contact "F". This short circuits the magazine motor armature (dotted lines), dynamically braking the magazine and bringing it to a quick stop. A circuit is simultaneously completed to the gripper motor through the relaxed cancel relay contacts, causing it to engage the indexed record.

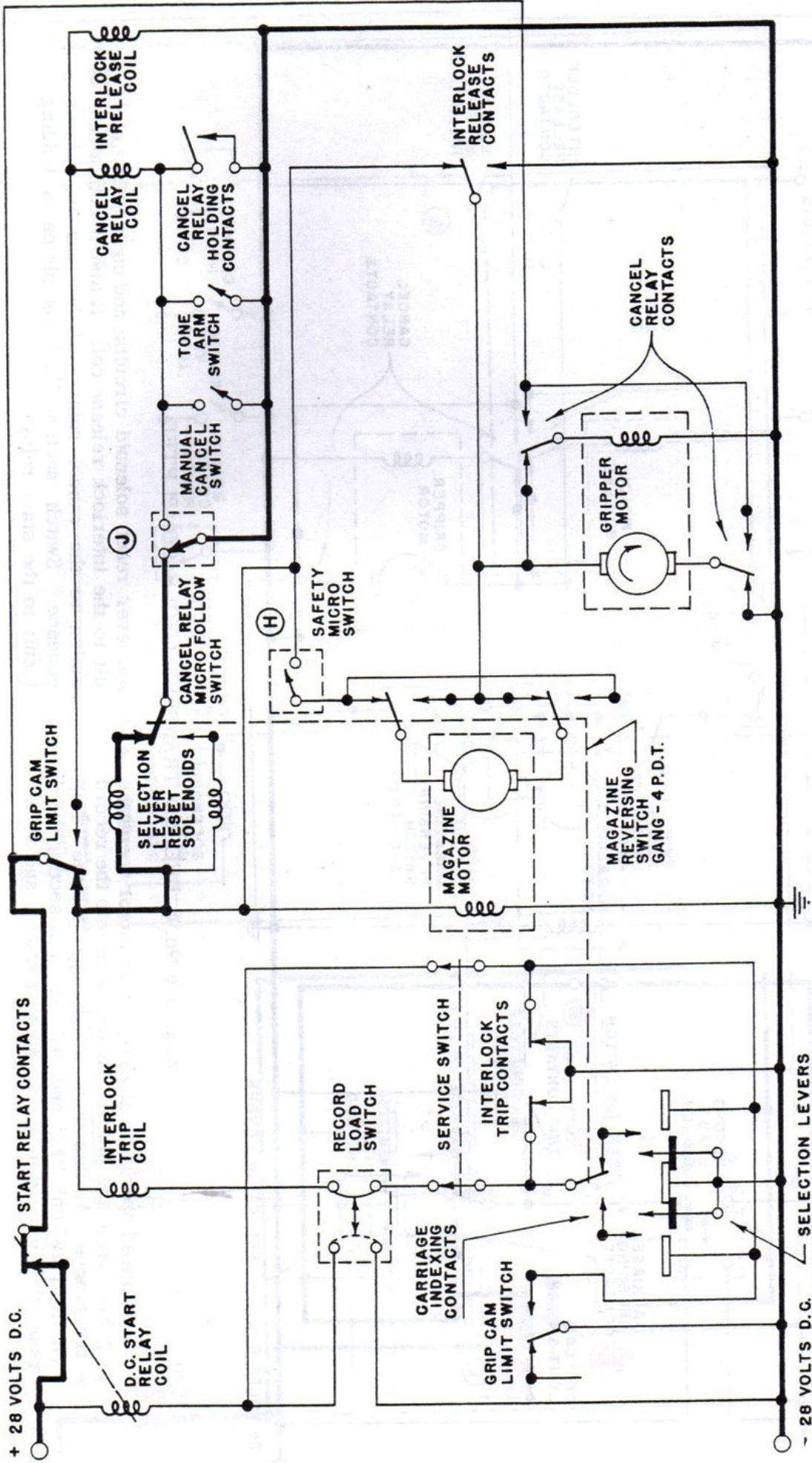

Sequence No. 5 SELECTOR LEVER RESET

Just prior to the grip jaws engaging the record, a cam operates the "Safety micro switch", "H", thereby disconnecting the magazine motor armature. The grip-motor continues to operate and places the record on the turntable. At this point, the "Cancel relay follow

switch "J" operates and closes the circuit to the proper "Selection lever reset solenoid". This causes a spring plunger to push the registered selector lever to its normal position.



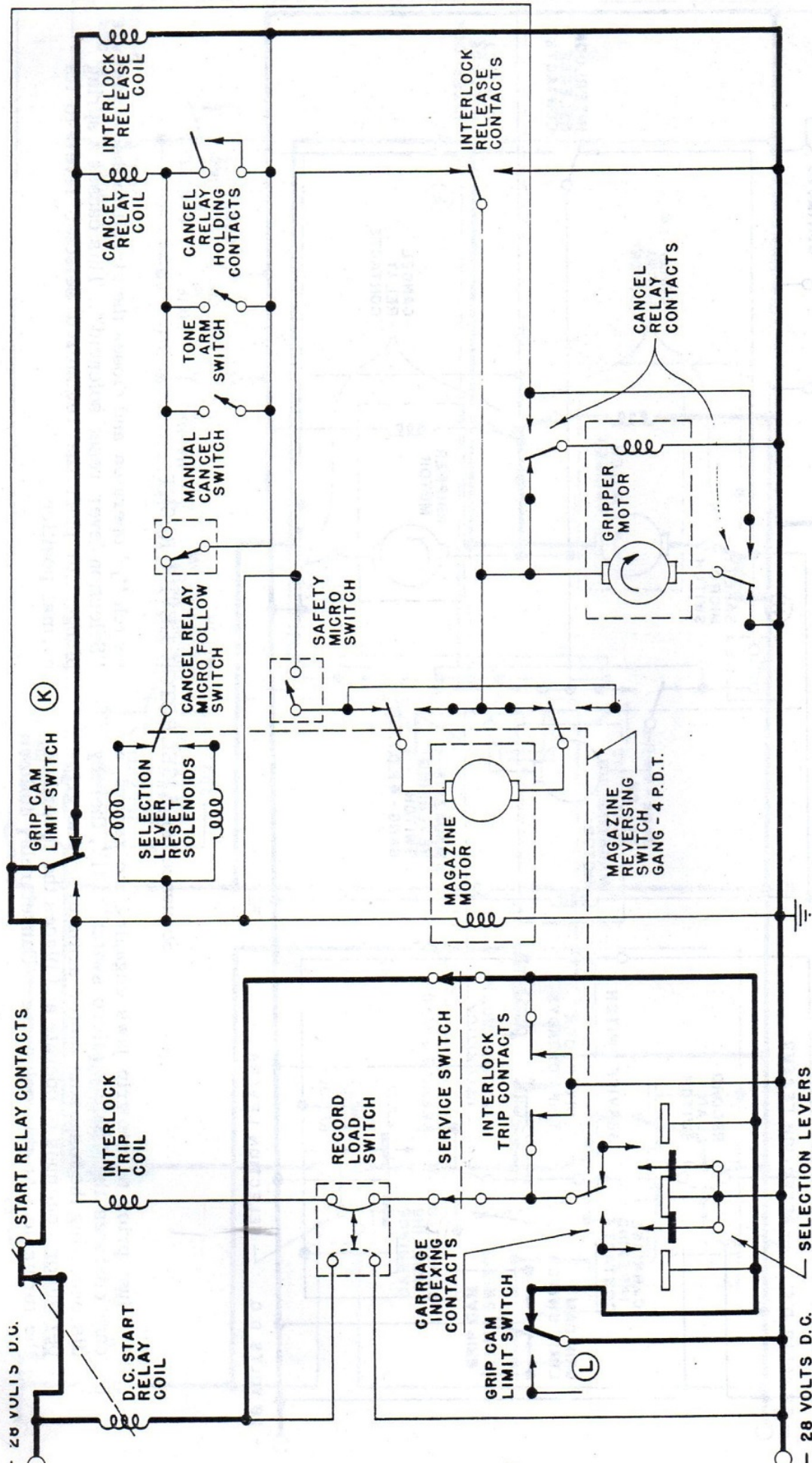

Sequence No. 6 RECORD TRANSFER CYCLE COMPLETED

Continued operation of the gripper motor opens the grip arm jaws and places the tone arm into the record entry groove. At this point, a cam operates the "Grip cam limit switch", "K", and "L". Switch section "K" breaks the interlock trip coil, gripper motor, and selec-

tion lever reset solenoid circuits, and completes a circuit to the interlock release coil. It also makes a connection to the cancel relay coil for use in a later sequence. Switch section "L" completes a holding circuit to the start relay.

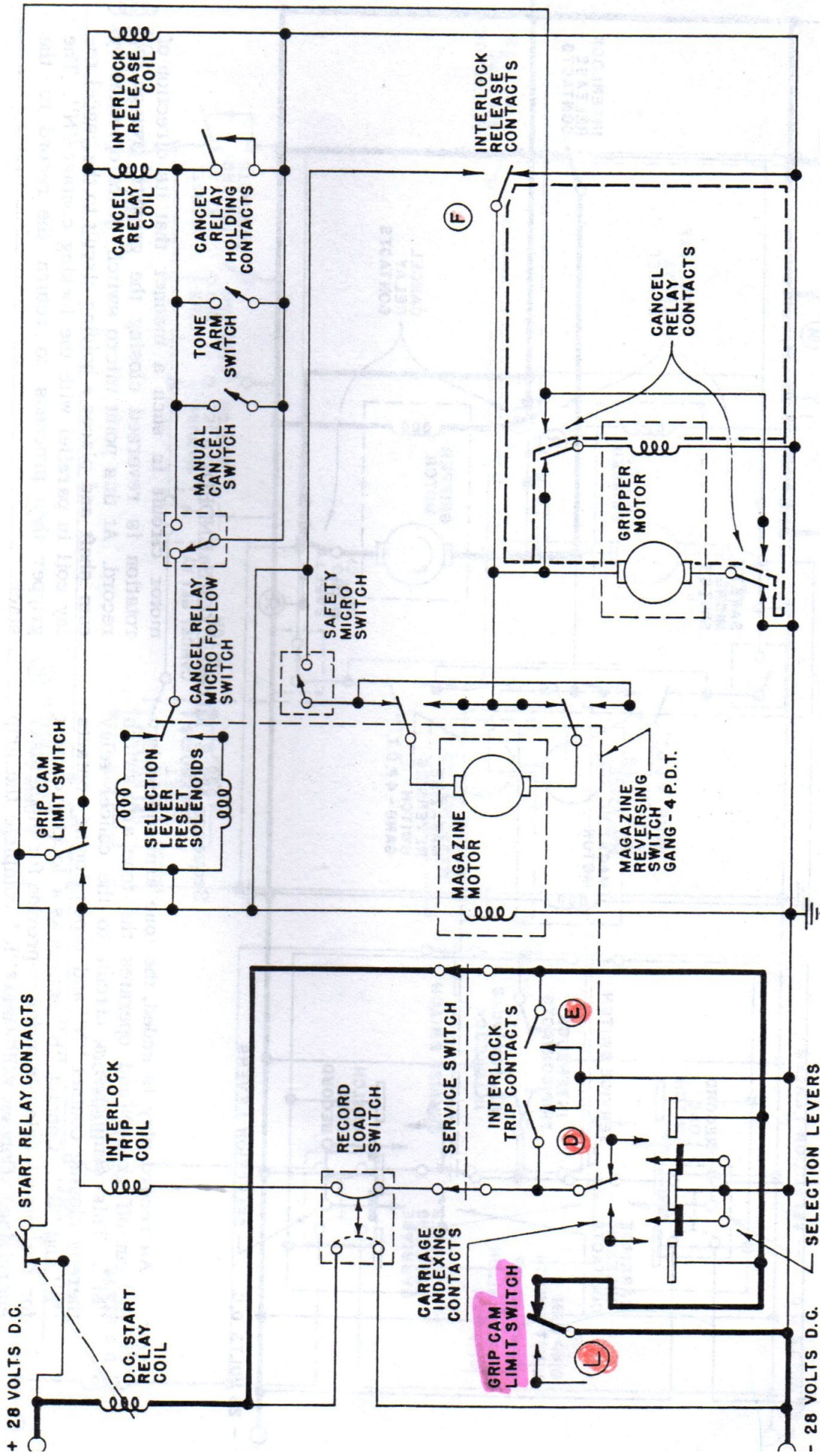

Sequence No. 7 GRIP MOTOR STOPS

The energized "Interlock release armature" places contact "F" in its original position. This places a short circuit across the gripper motor, dynamically braking it and stopping the grip mechanism. As the "Interlock release armature" completes its stroke, the

"Interlock trip armature" relaxes, thereby opening contacts "D" and "E". Contact "E" removes the holding action from the start relay, which is now being held by the "Grip cam limit switch" contact "L". Music cycle now begins.

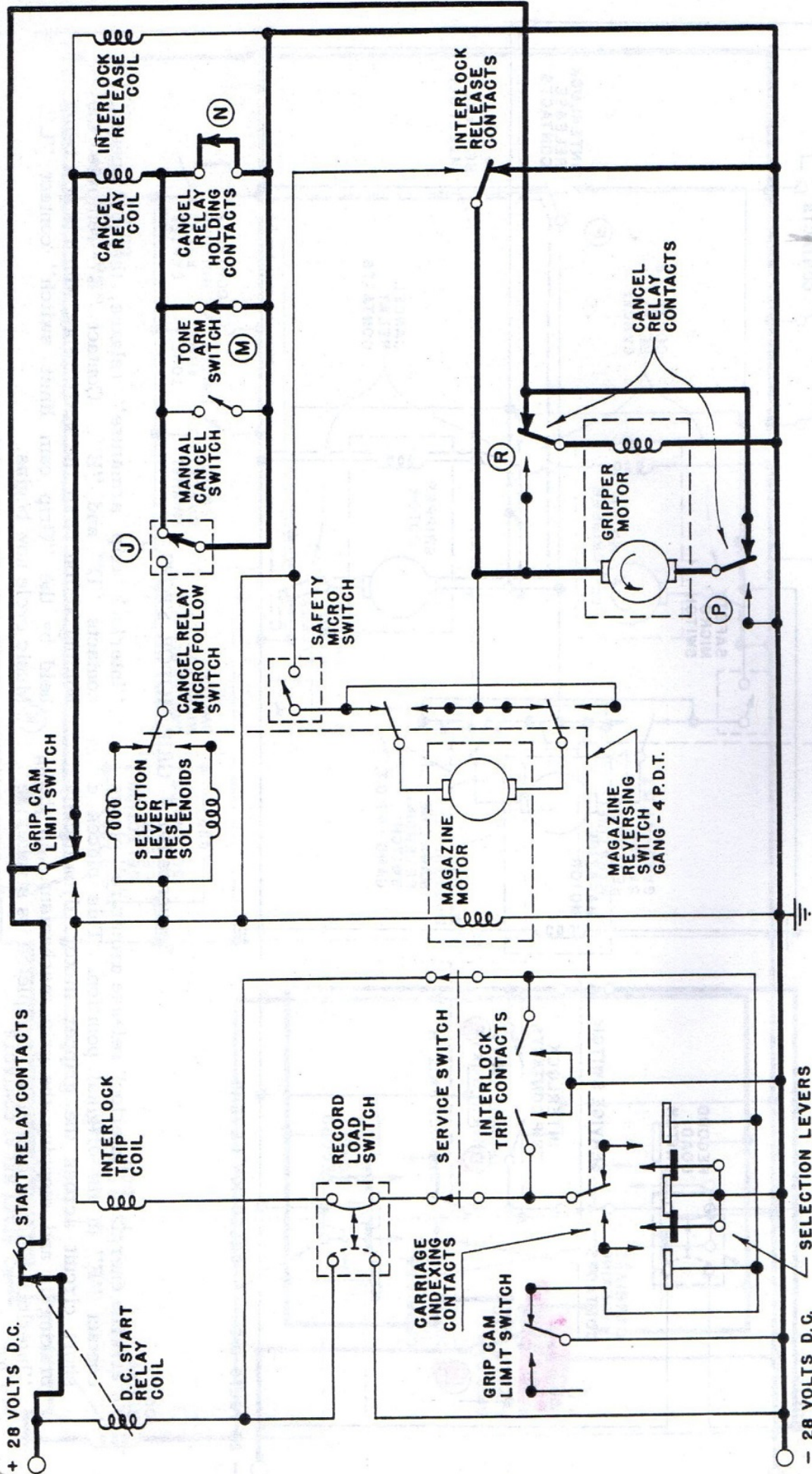

Sequence No. 8 MUSIC CYCLE ENDED

As record play is ended, the tone arm moves into the cut-off groove and operates the tone arm switch "M". This completes a circuit to the cancel relay thereby closing contact "N" and repositioning contacts "P" and "R". Contact "N" serves as a locking contact for the cancel relay in order to provide for momentary energizing. Contact "P" and "R" complete the grip

motor circuit in such a manner that its direction of rotation is reversed closing the gripper jaws on the record. At this point micro switch "J" is operated by cam shaft and places a holding circuit to the cancel relay coil in parallel with the locking contact "N". The gripper then proceeds to return the record to the stack.

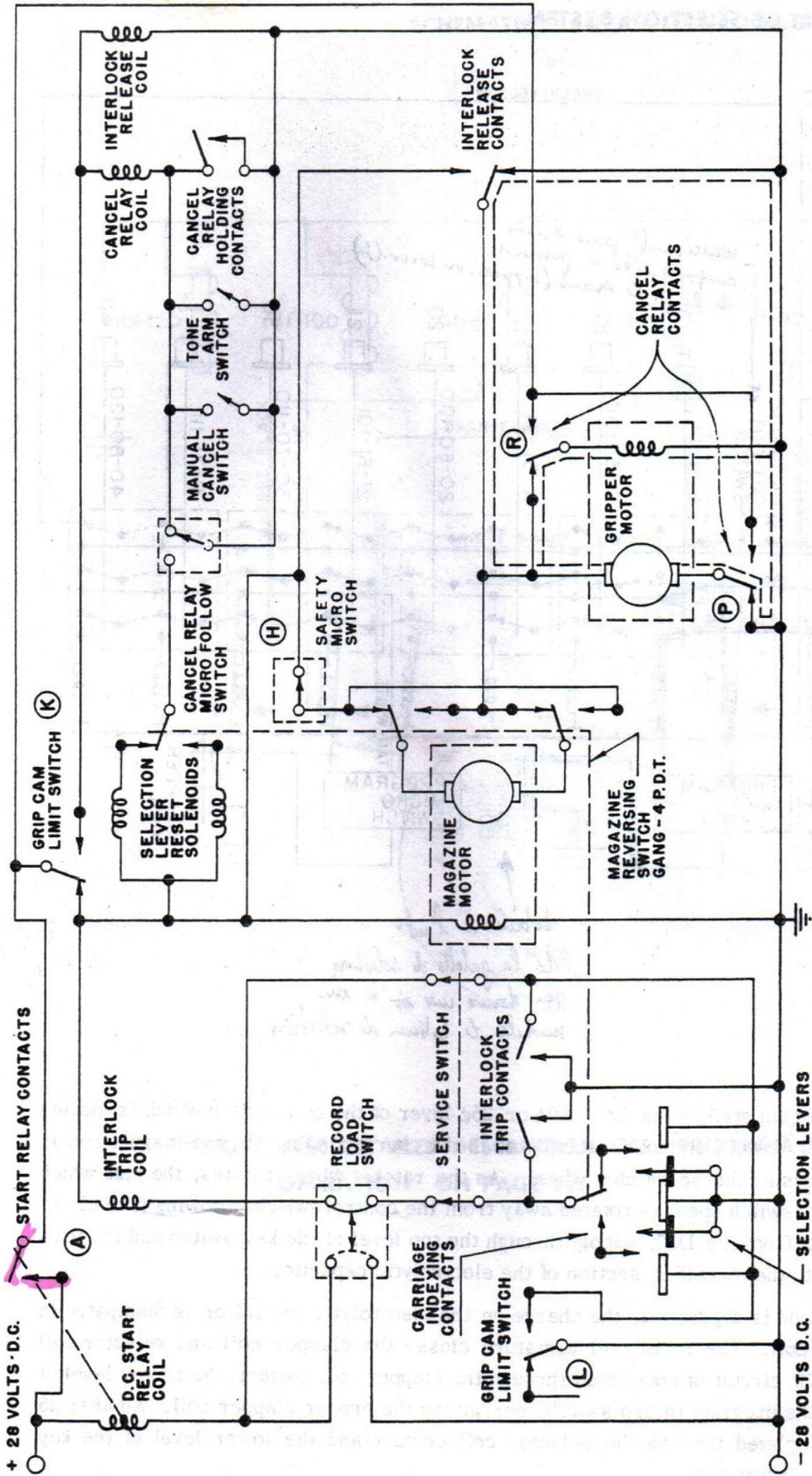

Sequence No. 9 CYCLE COMPLETED

As the grip arm jaws begin to release the record in the magazine, the camshaft re-closes the safety micro switch "H". After the grip arm jaws open, the camshaft resets the grip cam limit switch "K" and "L". Section "K" opens the cancel relay circuit, thereby allowing the relay to relax, and section "L" opens the start relay circuit. provided no additional selections

This opens contact "A" thus shutting off power to the D.C. motors, and also opens the amplifier and turntable power circuits. Contacts "P" and "R" return to their relaxed positions and short-circuit the gripper motor, which brakes to a stop.

# SCHEMATIC DIAGRAM OF SELECTION SYSTEM

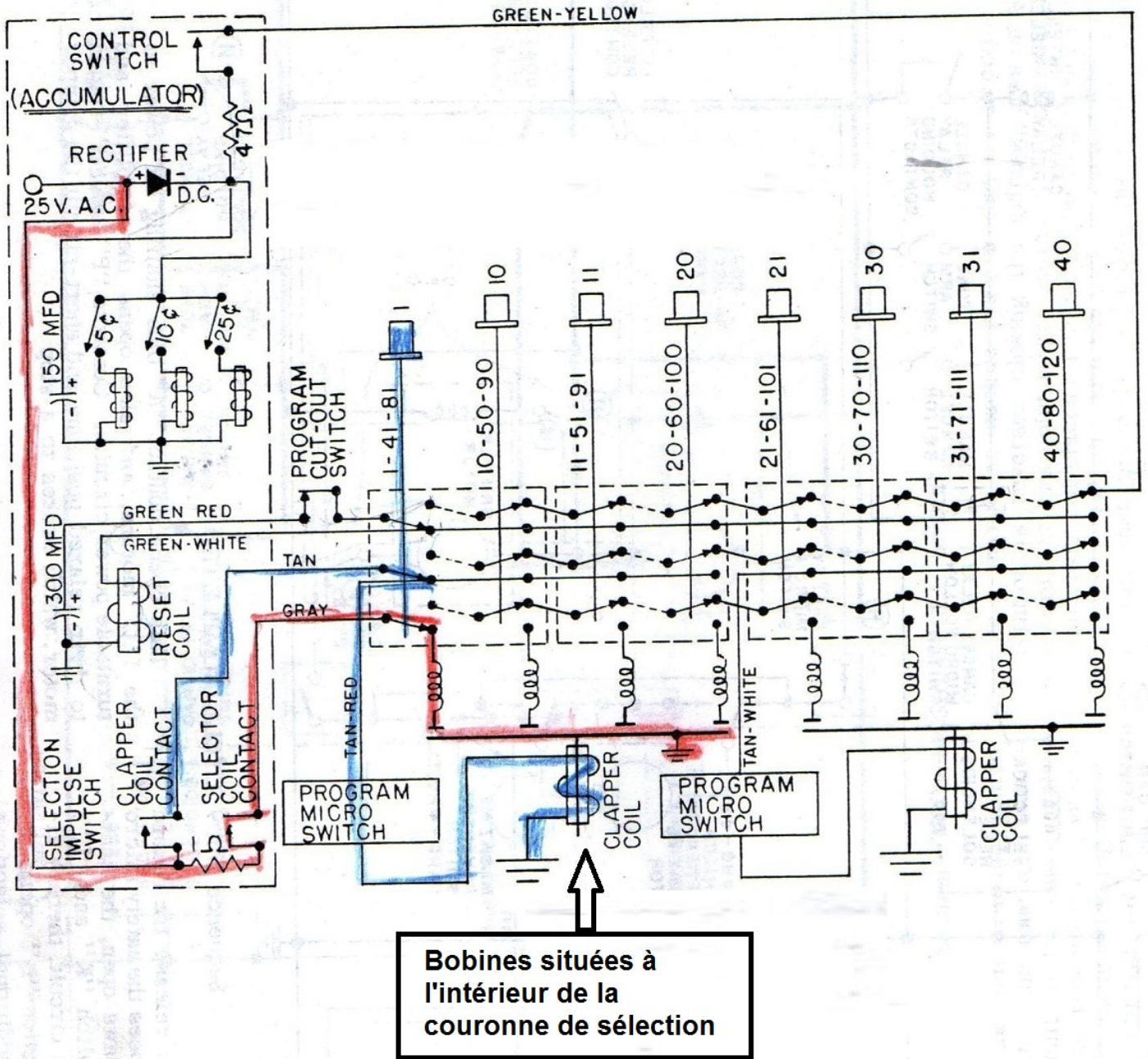

When a deposited coin strikes the 5¢ - 10¢ or 25¢ lever of the coin switch which is located below the slug rejector, a D.C. circuit is completed to the corresponding electro-magnet coil in the accumulator, releasing the 5¢ ratchet wheel. As the ratchet wheel rotates, the stud which was holding the control switch open, is rotated away from the control switch, allowing it to close. A circuit is completed from the D.C. supply through the top level of the key switch and the program cut-out switch, to the 300 MFD. section of the electrolytic capacitor.

As a selector button is depressed, the charge on the electrolytic capacitor is dissipated in energizing the reset coil. The reset coil armature closes the clapper coil and selector coil contacts. A 25 V.A.C. circuit is completed through the clapper coil contact, the center level of the key switch, and the program micro switch, energizing the proper clapper coil. Another 25 V.A.C. circuit is completed through the selector coil contact and the lower level of the key

# SCHEMATIC DIAGRAM OF PROGRAM PANEL OPERATION

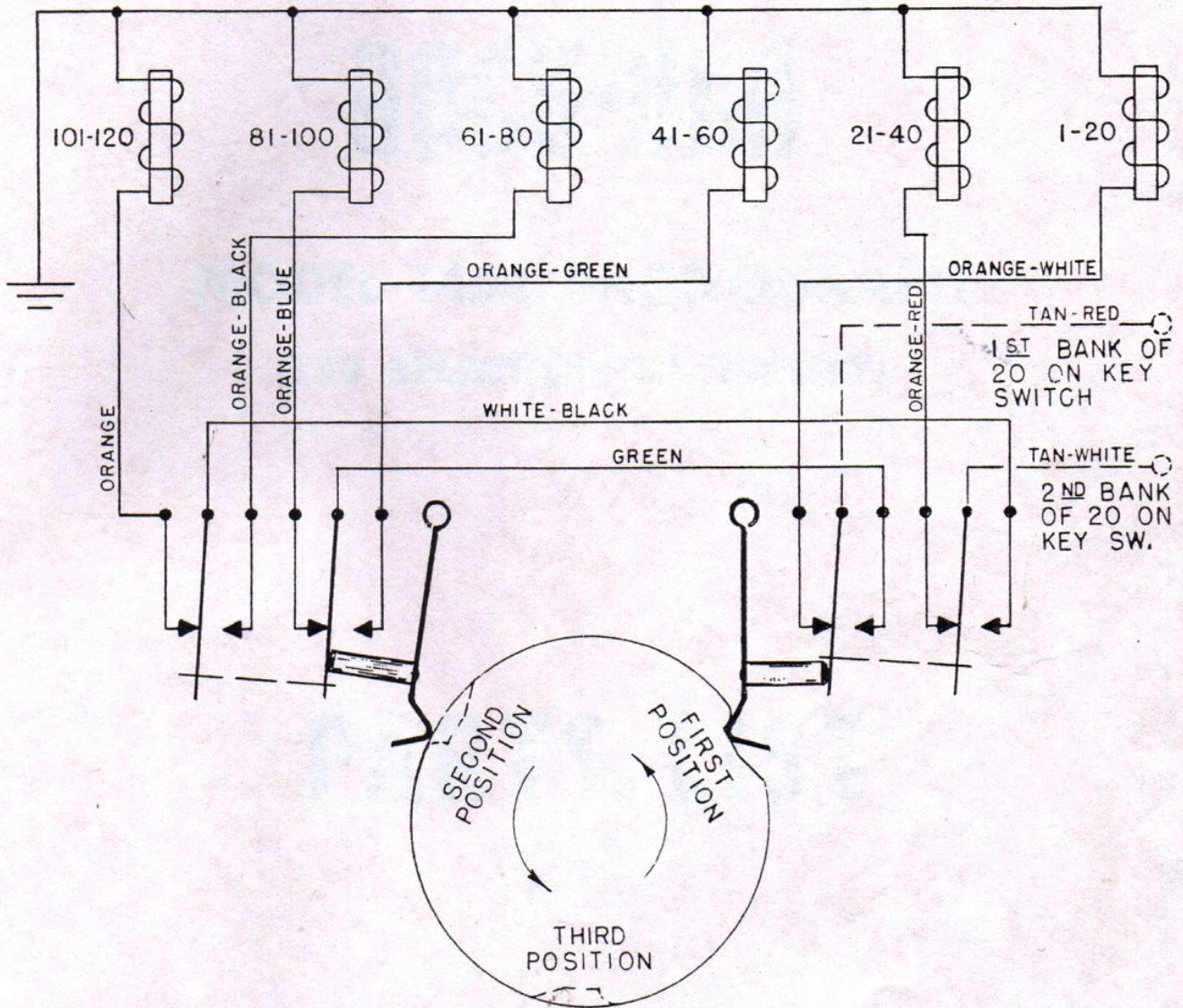

**NOTE: FOR DETAILED DESCRIPTION, SEE "PROGRAM PANEL OPERATION" ON PAGE 11.**

# PART LIST CATALOG

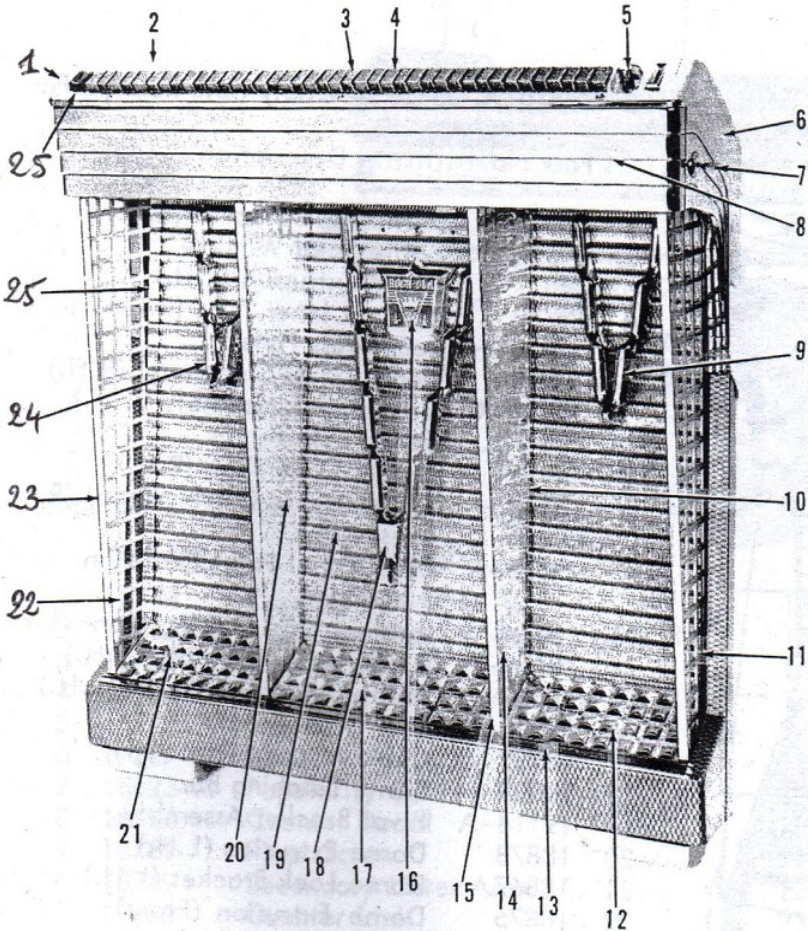

No. 19665-A Door Assembly (Front View)

Part No.	Description
1	18746-1 Door Side Casting (L.H.)
2	18751 Key Plate
3	19624 Key Switch Button (Blue)
4	18740 Key Switch Button (Amber)
5	19155-A Reject Button and Cable Ass
6	18745-1 Door Side Casting (R. H.)
7	ST-7394 Front Door Lock
8	18742 Door Front Casting
9	18749 Grille Trim Casting (Small)
10	19766-A Glass Trim Moulding (Rear)
11	19693 Grille Side Dress Piece
12	19588 Chrome Trim (End)
13	19785 Base Trim Moulding
14	18790 Grille Glass (R.H.)
15	19780 Glass Moulding
16	19622 R.M.C. Emblem
17	19589 Chrome Trim (Center)
18	18750 Grille Trim Casting (Large)
19	19769-A Perforated Grille Assembly
20	18791 Grille Glass (L.H.)
21	19588 Chrome Trim (End)
22	19693 Grille Side Dress Piece
23	19779 Grille Side Moulding (Front)
24	18749 Grille Trim Casting (Small)
25	19768-A Grille Side Moulding (Rear)
26	18753 Program Change Button

No. 19665-A Door Assembly (Rear View)

Part No.	Description
1	19236-A Cam Arm and Connector Assembly
2	19185-A Reject Bracket and Stop Assembly
3	19022 Flexible Chute
4	17760 Reject Cable Housing
5	19692 Grille Color Shield
6	19188-A Lock Cam Riveting Assembly
7	18869 Locking Arm Guide (L.H.)
8	18724 Key Switch (Rear)
9	18723 Key Switch (Front)
10	18724 Key Switch (Rear)
11	18723 Key Switch (Front)
12	18906 Program Change Switch
13	19234 Program Change Button Spring
14	18868 Locking Arm Guide (R.H.)
15	11556 Fluorescent Light Starter
16	19122 Ballast
17	16815 12 Contact Socket and Shell

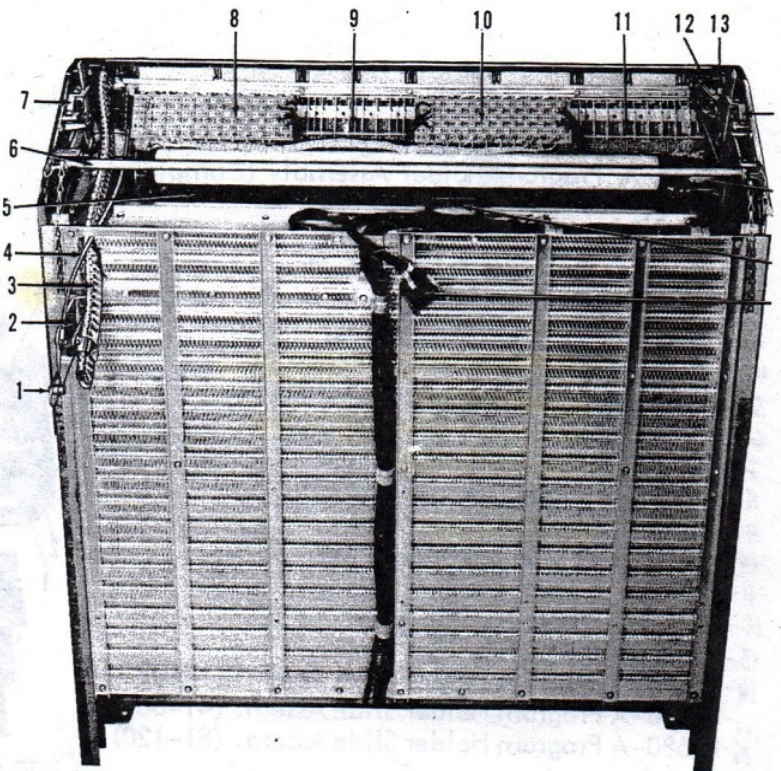

No. 19670-A Dome Assembly (and Related Par

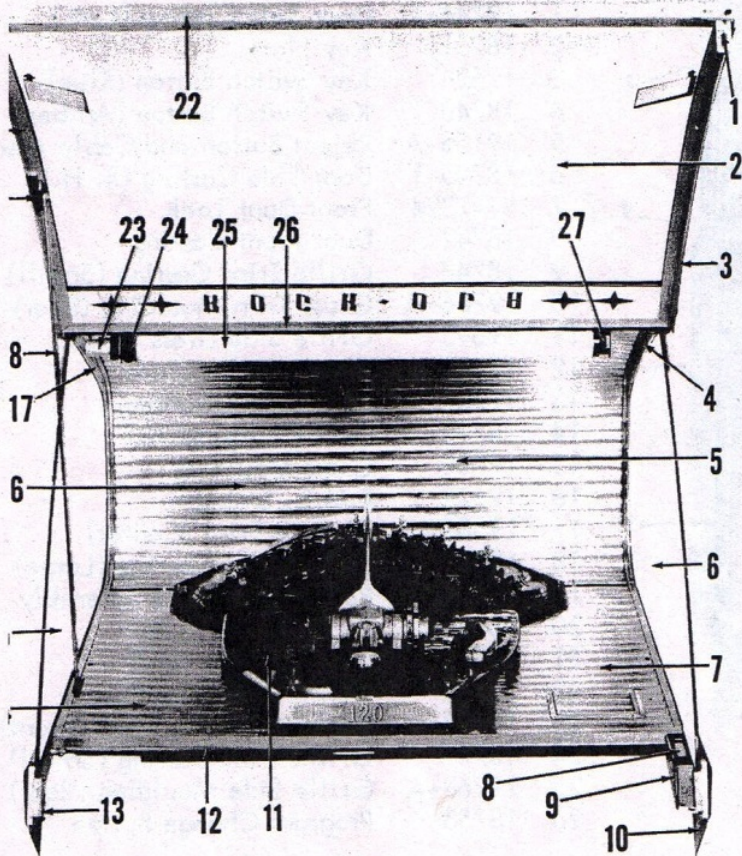

Part No.	Description
1 18866	Dome Lock Bracket (R.H.)
2 19594	Dome Front Window
3 18877	Dome Extrusion (R.H.)
4 18738	Cabinet Inner Trim (R.H.)
5 19638	Rear Dress Panel
6 19598	Dome Glass Side Panel (R.H.)
7 19688-A	Dress Panel Assembly (R.H.)
8 19061	Select Glass
9 18932	Corner Cover Cap (R.H.)
10 18743	Cabinet Side Casting Front (R.H.)
11 19685	Dress Cap
12 19683-A	Dress Panel Front Extrusion Assembly
13 18744	Cabinet Side Casting Front (L.H.)
14 19689-A	Dress Panel Assembly (L.H.)
15 19599	Dome Glass Side Panel (L.H.)
16 19638	Rear Dress Panel
17 18739	Cabinet Inner Trim (L.H.)
18 19021	Dome Latching Bar
19 19114-A	Pivot Bracket Assembly
20 18878	Dome Extrusion (L.H.)
21 18867	Dome Lock Bracket (L.H.)
22 18875	Dome Extrusion (Front)
23 11556	Fluorescent Light Starter
24 19119	Fluorescent Light Socket
25 19264	Fluorescent Tube
26 18876	Dome Extrusion (Back)
27 19119	Fluorescent Light Socket

d. 19666-A Program Holder Assembly (Complete)

Part No.	Description
1-19010	Program Friction Spring
2-18730	Program Gear
3-18729	Program Drive Gear
4-19048-A	Cut-Out Switch Assembly
5-11609	Micro Switch
6-19042-A	Switch Lever Assembly
7-11609	Micro Switch
8-18929	Program Drive Motor
9-18857	Program Relay
10-16816	12 Contact Male Plug
11-19609	Program Extrusion
12-18910	Program Main Shaft
13-18943	Index Tab
14-19676-A	Program Holder Slide Assem. (1-40)
15-19678-A	Program Holder Slide Assem. (41-80)
16-19680-A	Program Holder Slide Assem. (81-120)

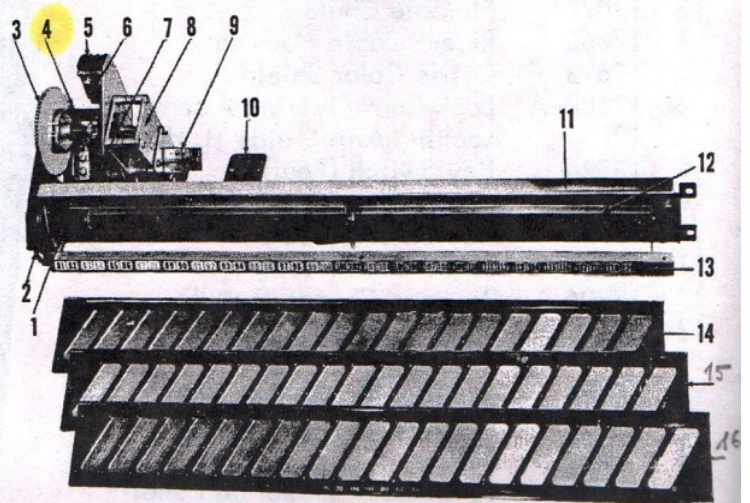



No. 19714-A Accumulator Assembly  
Complete

Part No.	Description
1	17992-A Reset Armature Riveting Assembly
2	14570 Tension Spring
3	14567 Spring Anchor
4	14014 Armature - Ratchet
5	14018 Spacer
6	14017 Spacer - Ratchet Detent
7	14011 Coil - Electromagnet
8	14579-A Ratchet Escapement Armature Assembly

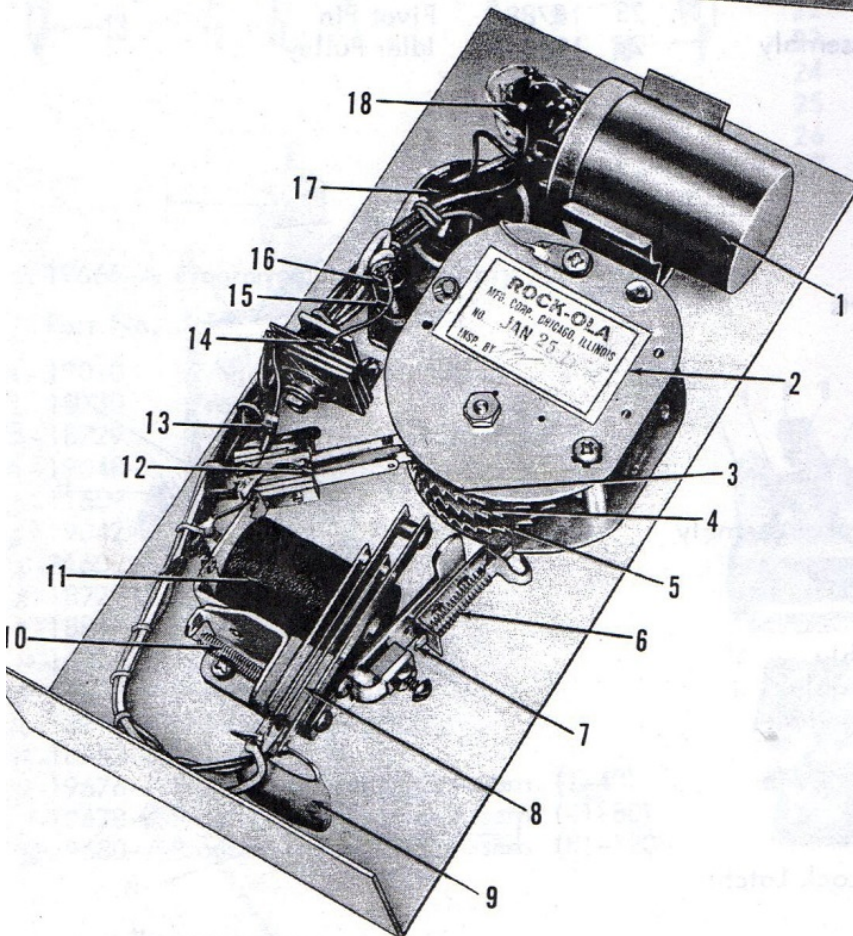
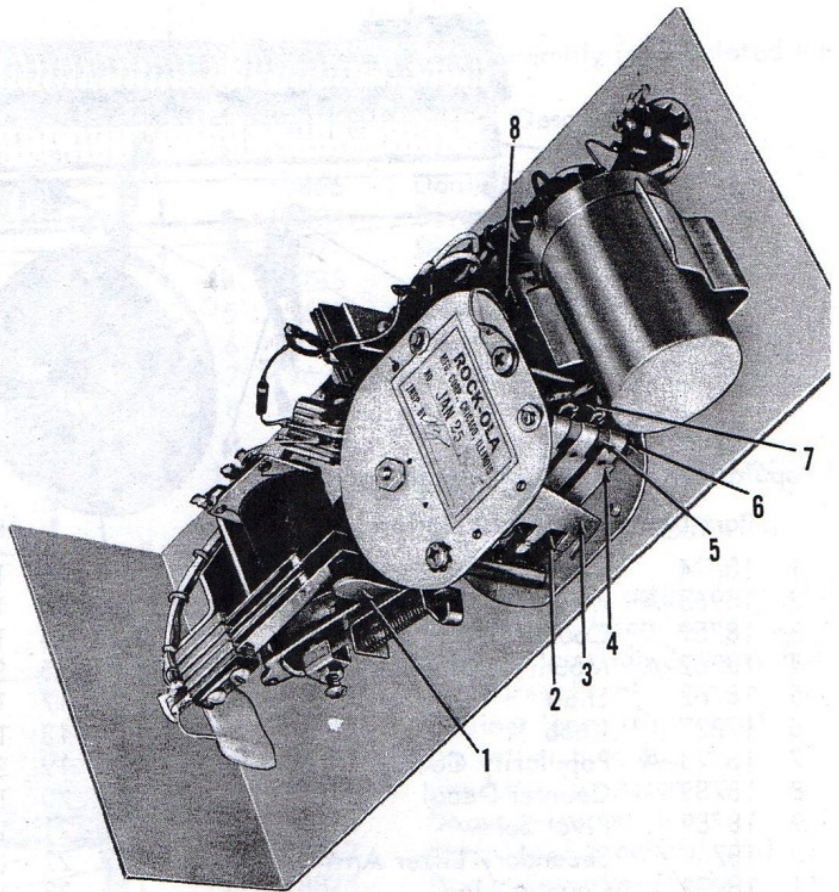

No. 19714-A Accumulator Assembly  
Complete

Part No.	Description
1	14416 Accumulator Capacitor
2	14580-A Accumulator Assembly
3	14035-A 25¢ Ratchet and Hub Assembly
4	14036-A 10¢ Ratchet and Hub Assembly
5	14037-A 5¢ Ratchet and Hub Assembly
6	14028 Compression Plate
7	17982 Pawl - Reset
8	14415 Switch - Selection Impulse
9	19213 1 Ohm 5 Watt Resistor
10	19216 Tension Spring
11	14030 Coil - Reset
12	15392-A Control Switch Assembly
13	14097 47 Ohm 1/2 Watt Resistor
14	16812 Rectifier
15	11555 Fuse Holder
16	ST-4306 1/10 Amp. Fusetron
17	16871 8 Prong Male Plug
18	18634 6 Prong Miniature Socket

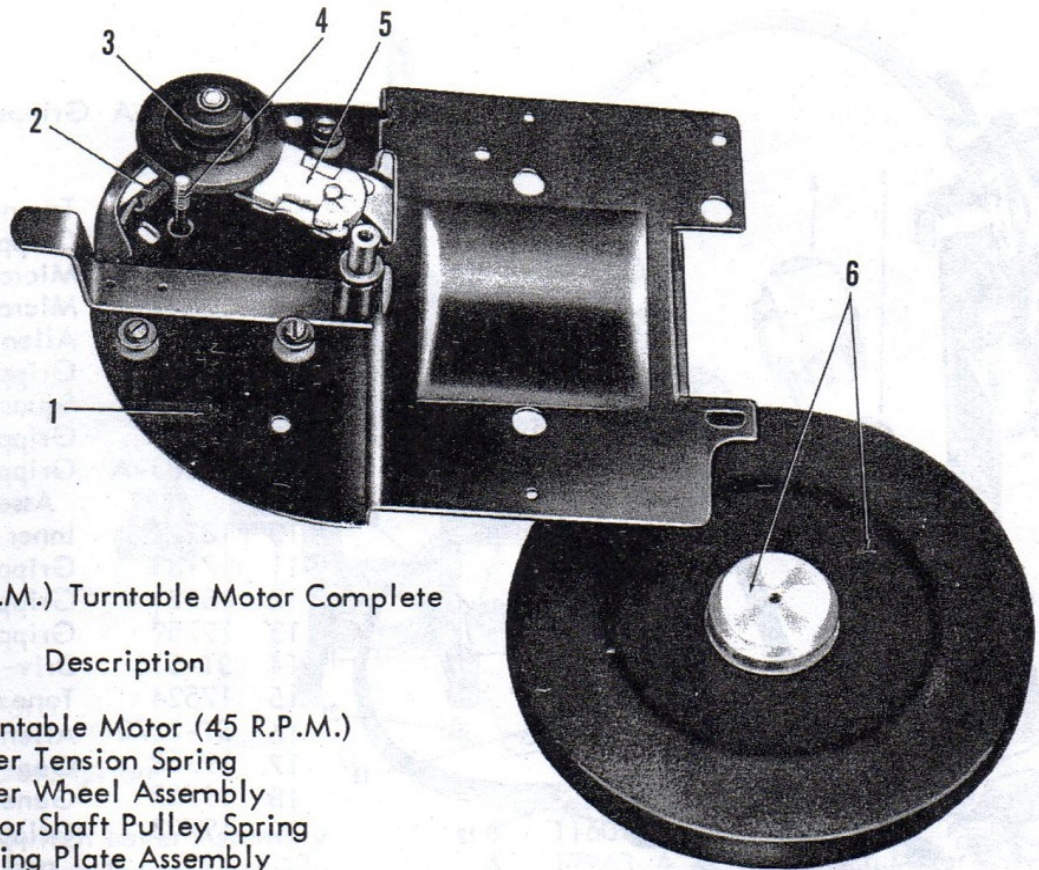

No. 18940 (45 R.P.M.) Turntable Motor Complete

Part No.	Description
1 18940	Turntable Motor (45 R.P.M.)
2 17149	Idler Tension Spring
3 17148	Idler Wheel Assembly
4 17151	Rotor Shaft Pulley Spring
5 17150	Spring Plate Assembly
6 17160	Turntable with Center Locator

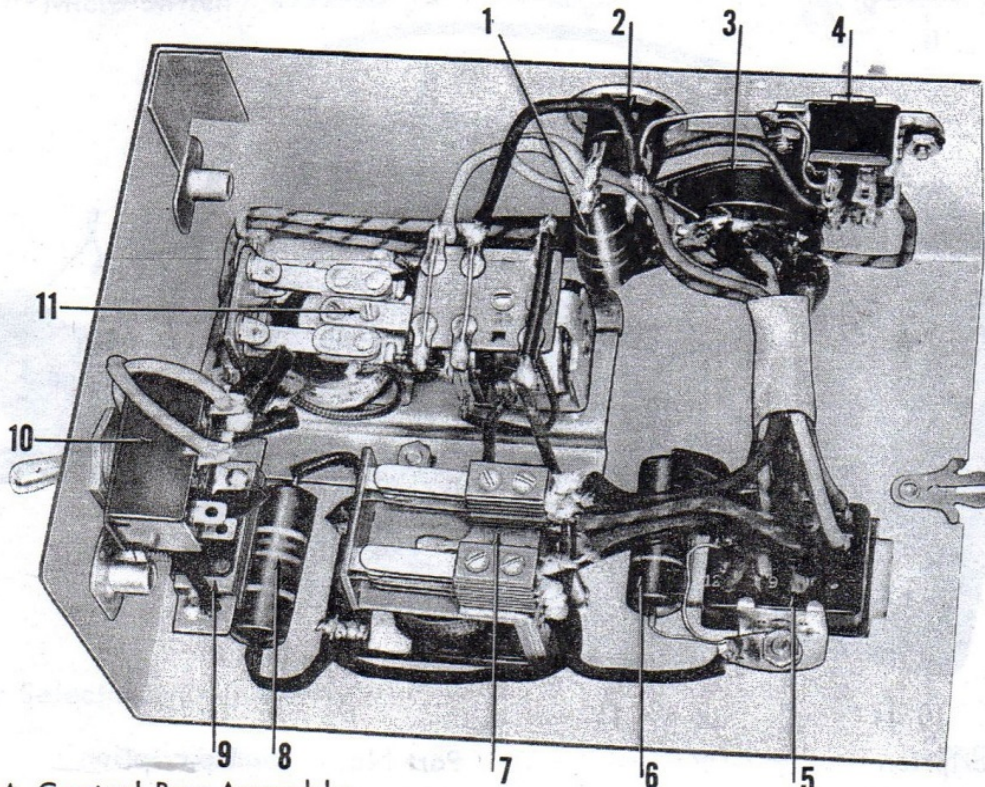

No. 19718-A Control Box Assembly

Part No.	Description	Part No.	Description
1 14365	.05 MFD. 400 V. Condenser	7 18858	Cancel Relay (D.C.)
2 16810	4 Prong Miniature Socket	8 14365	.05 MFD. 400 V. Condenser
3 PH-3732	8 Prong Socket	9 16913	Record Load Switch
4 17595	4 Prong Plug	10 16912	Mechanism Service Switch
5 16851	12 Contact Female Socket	11 17599	Interlock Relay
6 14365	.05 MFD. 400 V. Condenser		

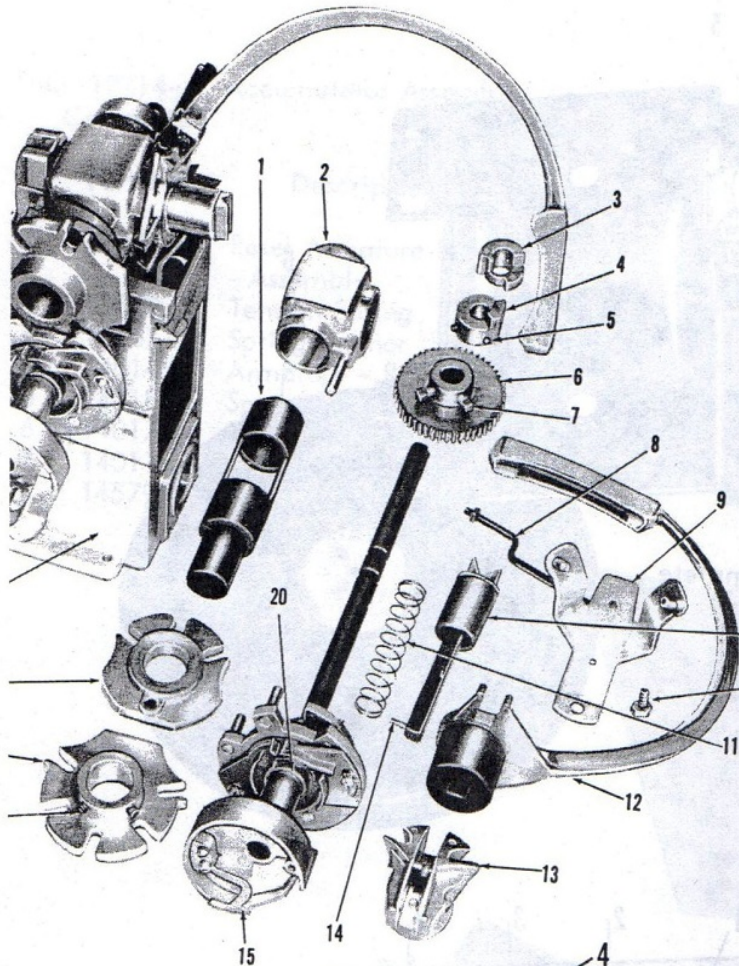

No. 19701-A Gripper Unit Assembly

Part No.	Description
1	18811-A Trunnion Shaft Assembly
2	19754-A Gripper Spider Assembly
3	16305 Micro Safety Cam - Outer
4	17679 Micro Safety Cam - Inner
5	ST-2262 Allen Set Screw
6	17470 Gripper Shaft Gear
7	ST-2244 Square Head Set Screw
8	16381 Gripper Connecting Rod
9	16683-A Gripper Reversing Bracket Assembly
10	18722 Inner Gripper Casting
11	17133 Gripper Spring
12	18721 Gripper Arm
13	19759 Gripper Arm Reversing Cam
14	ST-516 Driv-Loc Pin
15	17524 Tone Arm Cam Keeper Spring
16	ST-2270 Allen Set Screw
17	19758 Geneva Gripper Release
18	19757 Geneva Gripper Turn-over
19	19703 Gripper Housing (with Bearing and Stud Only)
20	17557-A Gripper Drive Shaft Assembly
21	16281 Shoulder Screw

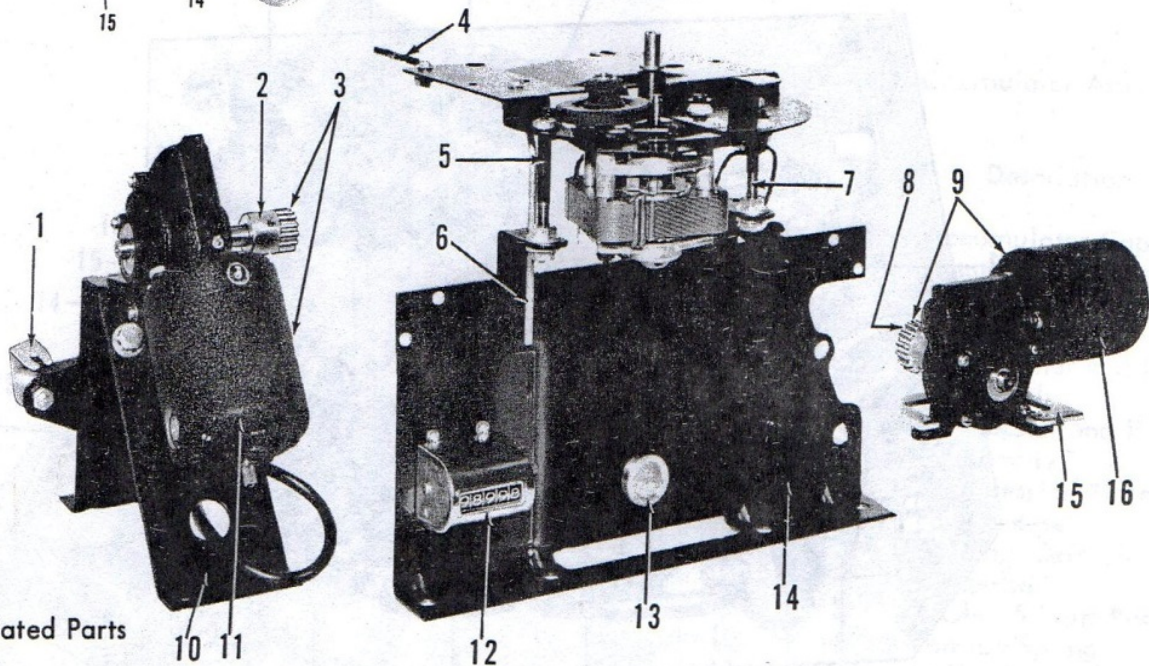

Parts and Related Parts

Part No.	Description	Part No.	Description
17840-A	Reversing Switch Assembly	9	18960-A Motor and Pinion Assembly
16279-1	Gripper Motor Gear	10	17837-A Motor Mounting Bracket Assembly
18961-A	Gripper Motor and Gear Assembly	11	18070 Magazine and Gripper Motor
19348	Counter Wire	12	12312 Counter
18786	Turntable Mounting Stud	13	19014 Selector Plate Bearing
19349	Counter Wire Housing	14	18821-A Mounting Bracket Assembly
18786	Turntable Mounting Stud	15	17170 Motor Clamping Plate
16440-1	Magazine Drive Pinion	16	18070 Magazine and Gripper Motor

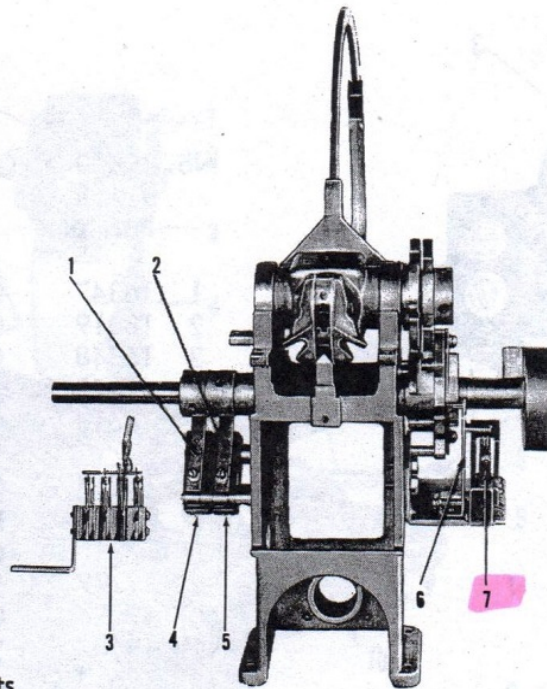

### Switches and Related Parts

Part No.	Description	Part No.	Description
1	17445-A Micro Switch Lever Assembly	5	11609 Micro Switch
2	17445-A Micro Switch Lever Assembly	6	17963-A Grip Switch Lever Assembly
3	17807-A Reversing Switch Assembly	7	16979-A Grip Cam Switch and Bracket Assembly
4	11609 Micro Switch		

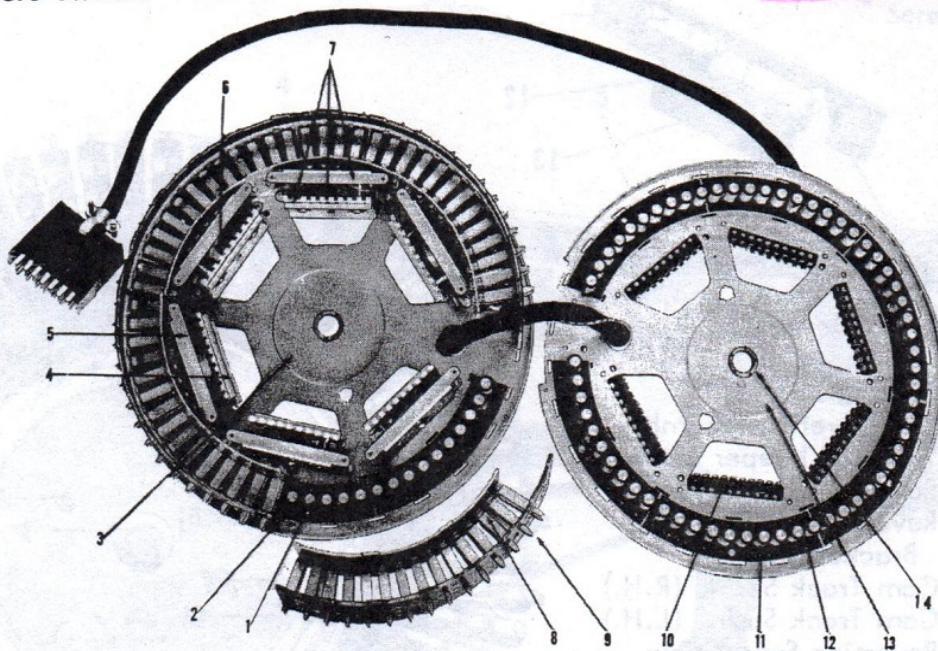

### No. 19576-A Selector Unit Assembly

Part No.	Description	Part No.	Description
1	16330 Selector Coil	7	16574-A Clapper Assembly
2	16313 Selector Insulation - Bottom	8	19150 Armature Spring
3	18958-A Selector Bottom Plate Assembly	9	19550 Selector Lever
4	16577-A Clapper Armature Riveting Assembly	10	16572-A Selector Strip Contact Assembly
5	16575-A Clapper Bracket Assembly	11	16313 Selector Insulator Bottom
6	16329 Clapper Coil	12	16330 Selector Coil
		13	18954-A Selector Top Plate Assembly
		14	19014 Selector Plate Bearing

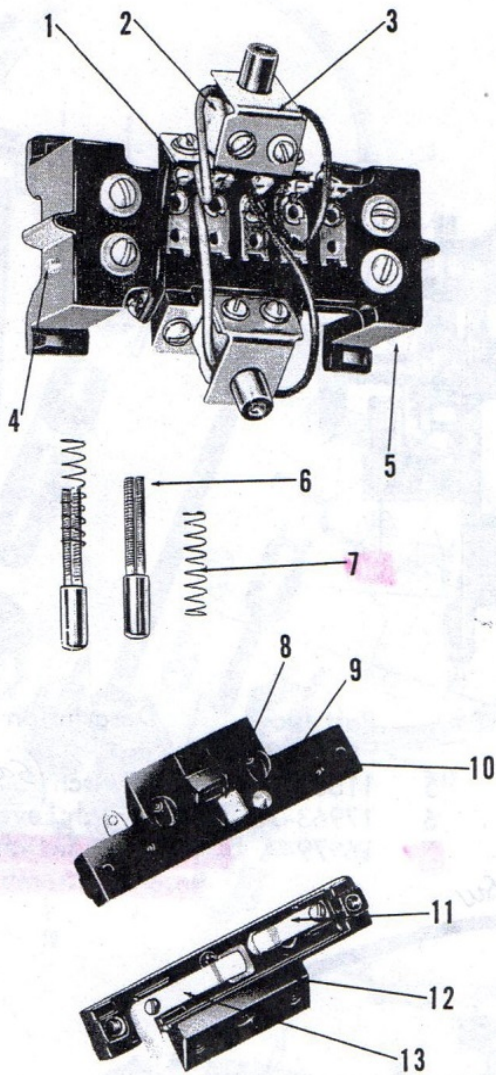

No. 19650-A Carriage Assembly Complete

Part No.	Description
1	16347 Coil Mounting Bracket
2	18019 Cancel Coil (D.C.)
3	16348 Coil Mounting Bracket
4	ST-2272 Allen Set Screw
5	16613-A Carriage Housing and Terminals (Only)
6	18018-A Coil Plunger Assembly
7	16346 Plunger Return Spring
8	17946-A Contact Assembly
9	19299 Spacer Pin
10	19596 Contact Block (Only)
11	19607 Spacer Pin Retainer
12	19653-A Carriage Contact Block Assembly
13	19608 Contact Retainer

No. 19566-A Record Magazine Assembly

Part No.	Description
1	16395 Tray Decal
2	19570-A Tray Riveting Assembly
3	19568-A Tray and Keeper Assembly
4	17310 Rubber Ring
5	17322 Reversing Switch Trip Bracket (R.H.)
6	17152 Cam Track Spring (R.H.)
6A	17153 Cam Track Spring (L.H.)
7	17323 Reversing Switch Trip Bracket (L.H.)
8	16263 Spacer Shaft
9	16645-A External Shaft Assembly
10	19290 Drive Gear
11	16250 Magazine
12	17312-A Record Keeper Assembly
13	17956 Record Keeper Spring

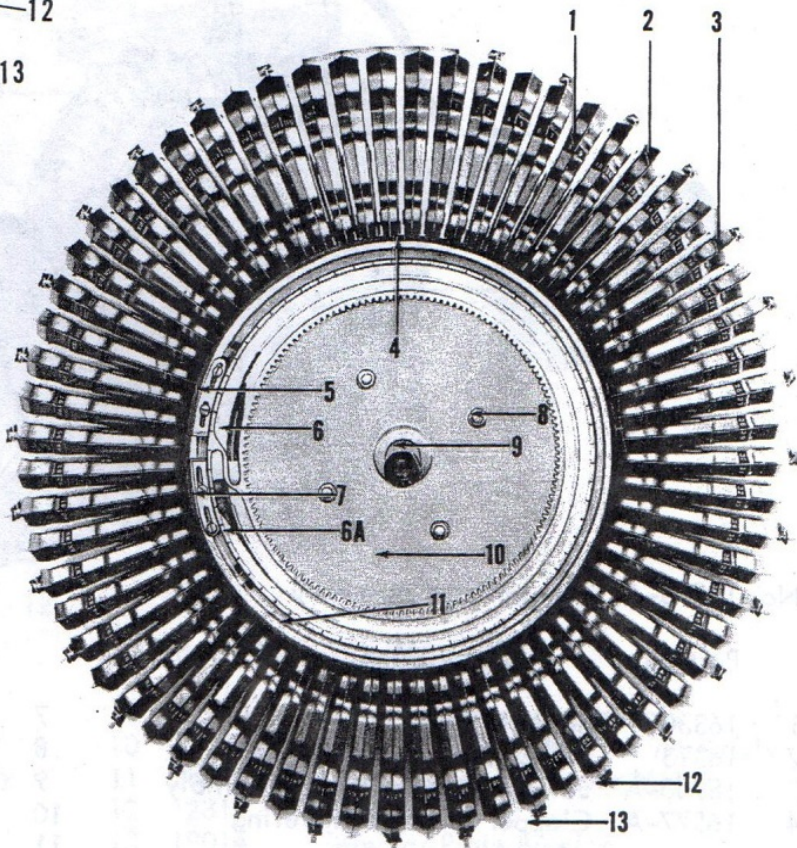

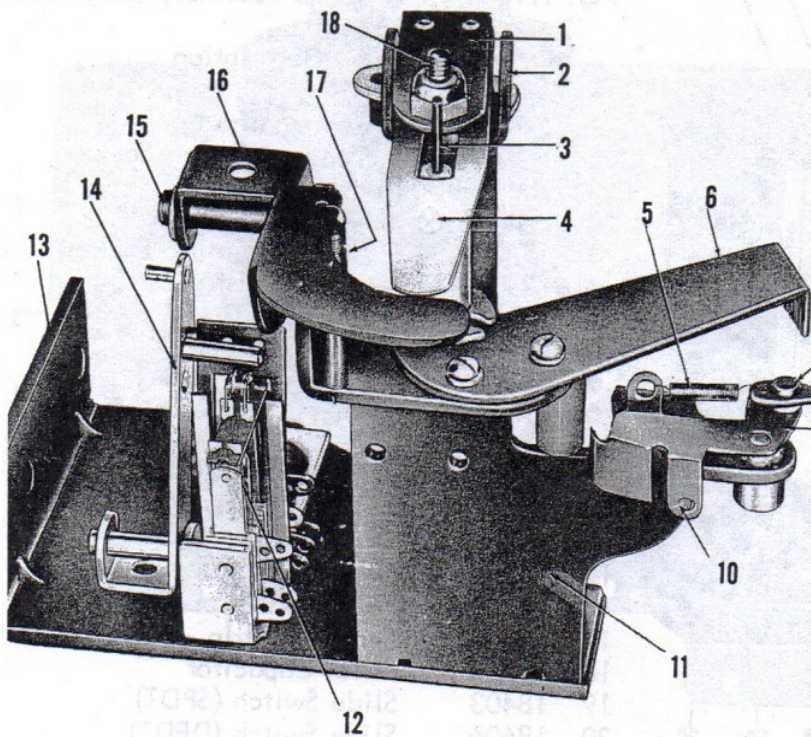

### Tone Arm Mounting

Part No.	Description
1	17779-A Pivot Plate Assembly
2	17521 Tone Arm Pivot Plate
3	17547 Tone Arm Rest Pin
4	17533 Tone Arm Spring
5	10901 Tension Spring
6	17616 Ratchet Plate
7	17540 Pawl Stud
8	17475 Tone Arm Pawl
9	17776-A Lever and Pawl Assembl
10	17543 Pawl Lever Spring
11	17774-A Tone Arm Bracket Assembly
12	16979-A Grip Cam Switch and Bracket Assembly
13	17473 Tone Arm Mounting Plate
14	17963-A Grip Switch Lever Assembly
15	17539 Lifter Lever Stud
16	17784-A Lifter Lever and Stud Assembly
17	17749 Lifter Lever Spring
18	ST-2279 8/32 x 1/2 Hollow Set Screw

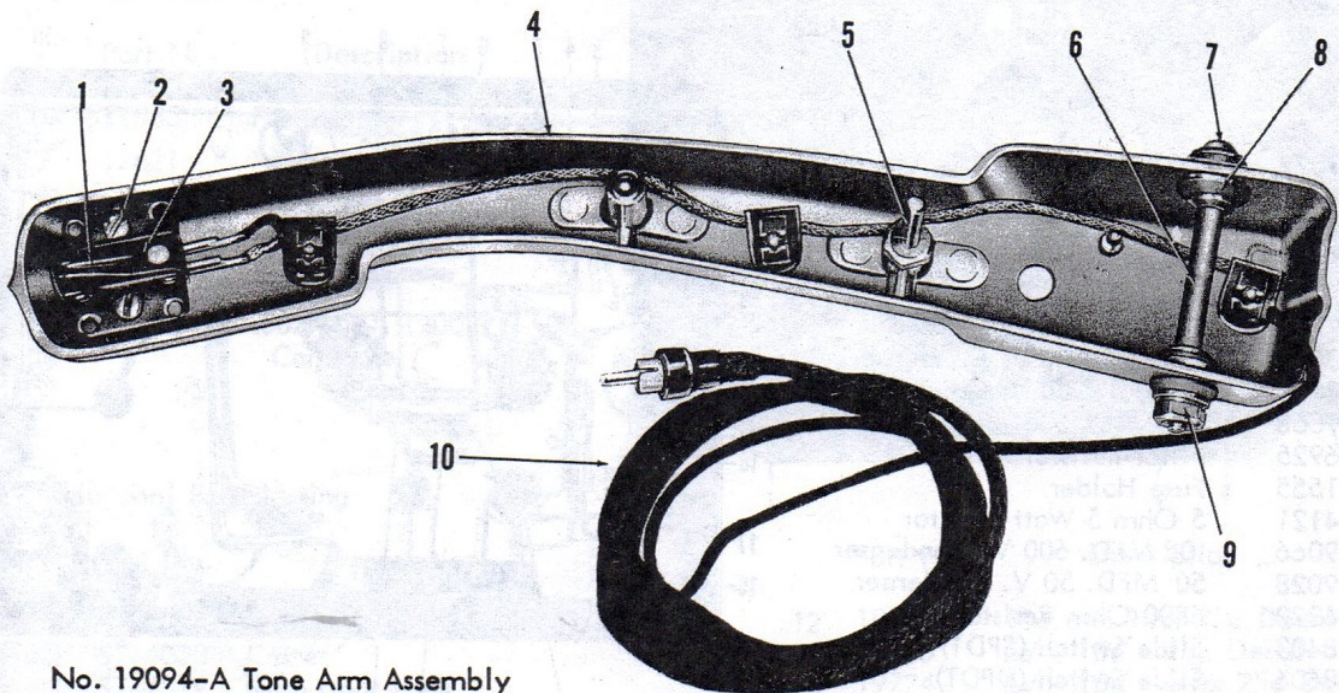

### No. 19094-A Tone Arm Assembly

Part No.	Description	Part No.	Description
1	18512 Hi-Fi Needle	6	17549 Tone Arm Bearing
2	ST-1543 Screw	7	ST-752 6/32 x 1 3/4 R.H.M.S.
3	18390 Ceramic Pickup Cartridge (45 R.P.M.)	8	17697 Tone Arm Grammet
4	17791-A Tone Arm Casting Assembly	9	ST-403 6/32 Hex Nut
5	17547 Tone Arm Rest Pin	10	19053 Input Cable

No. 19790-A Amplifier Assembly (Less Tubes)

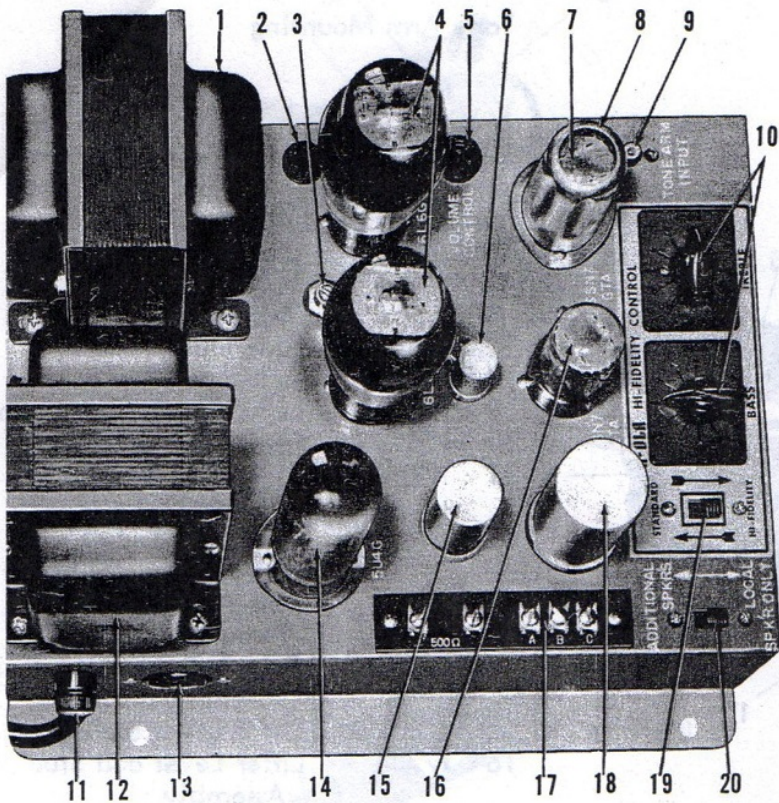

Part No.	Description
1	19002 Power Transformer
2	16810 4 Prong Miniature Socket
3	18411 Hum Control
4	PH-3191 6L6 Tube
5	18634 6 Prong Miniature Socket
6	18436 Standee Resistor
7	18385 6 SN7 GTA Tube
8	18412 Tube Shield
9	18402 Input Socket
10	11578 Pointer Knob
11	PH-3523 3 Amp. Fuse
12	19003 Output Transformer
13	18414 6 Prong Socket
14	PH-3190 5U4 Tube
15	16924 Input Capacitor
16	18385 6 SN7 GTA Tube
17	18401 Terminal Strip
18	16926 Filter Capacitor
19	18403 Slide Switch (SPDT)
20	18606 Slide Switch (DPDT)

No. 19790-A Amplifier Assembly (Less Tubes)

Part No.	Description
1	19072 .002 MFD. 400 V. Condenser
2	19076 15,000 ohm Resistor
3	13320 1 Megohm Resistor
4	18417 .01 MFD. 400 V. Condenser
5	17788 .47 MFD. 200 V. Condenser
6	19067 25 MFD. 15 V. Condenser
7	19075 .1 MFD. 200 V. Condenser
8	19075 .1 MFD. 200 V. Condenser
9	19066 .05 MFD. 600 V. Condenser
0	16925 Filter Resistor
1	11555 Fuse Holder
2	14121 5 Ohm 5 Watt Resistor
3	19066 .05 MFD. 600 V. Condenser
4	19028 50 MFD. 50 V. Condenser
5	16222 6800 Ohm Resistor
6	18403 Slide Switch (SPDT)
7	18606 Slide Switch (DPDT)
8	15403 27,000 Ohm Resistor
9	18651 Tone Control
0	13015 47,000 Ohm Resistor
1	19074 .01 MFD. 200 V. Condenser
2	19182 .033 MFD. 200 V. Condenser
3	19067 25 MFD. 15 V. Condenser
4	18651 Tone Control
5	19084 Audio Reactore

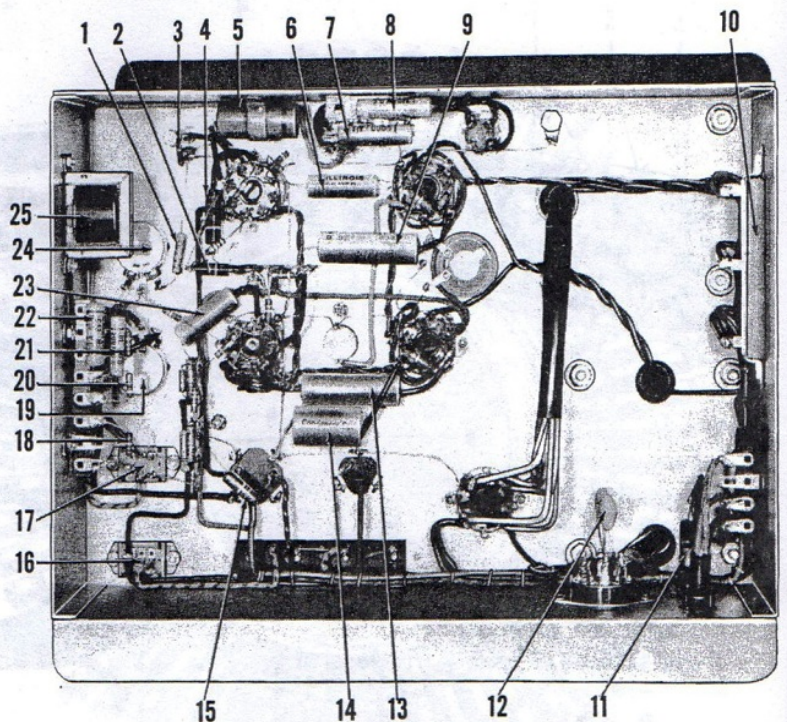

S C H E M A - D E - L , A M P L

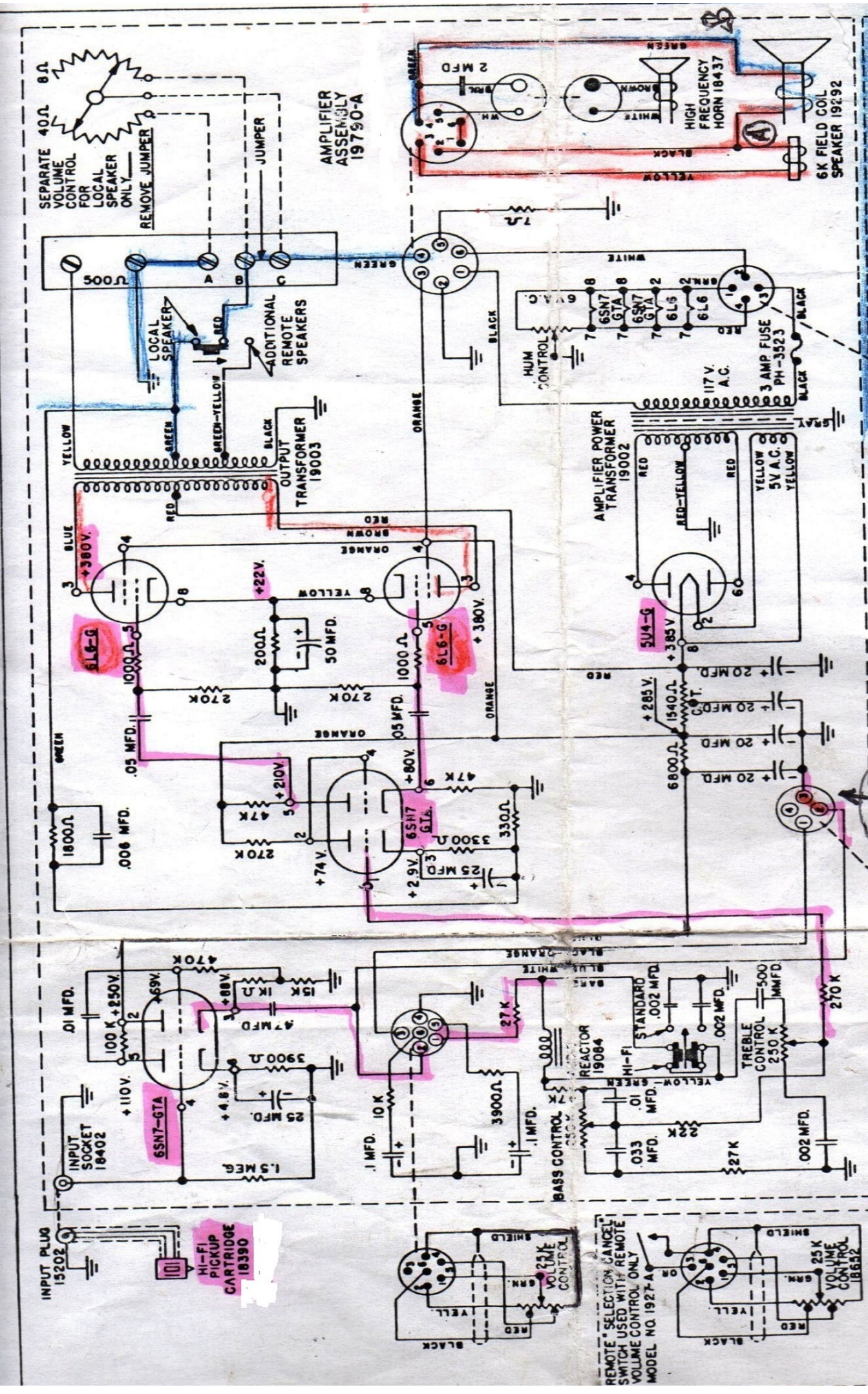

REMOTE \* SELECTION CANCEL \*  
SWITCH USED WITH REMOTE  
VOLUME CONTROL ONLY  
MODEL NO. 1927-A



No. 19705-A Power Distribution Panel Assembly

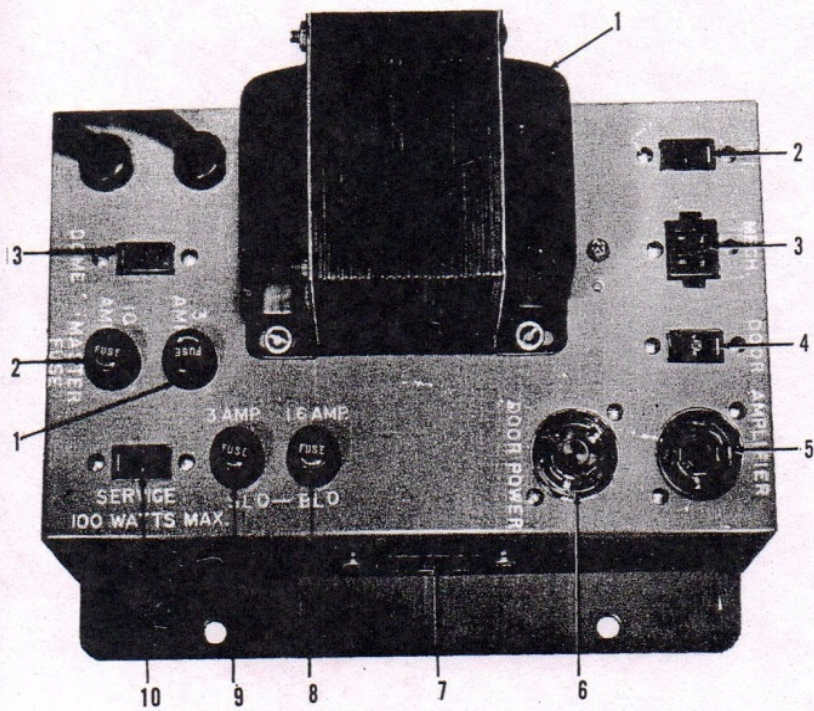

Part No.	Description
1 17604	Control Circuit Transformer
2 19006	Miniature Outlet
3 17596	4 Prong Socket
4 19006	Miniature Outlet
5 PH-3722	4 Prong Socket
6 PH-3740	5 Prong Socket
7 19008	6 Prong Jones Socket
8 ST-4321	1.6 Amp. Fuse
9 ST-3090	3 Amp. Slo-Blo Fuse
10 19006	Miniature Outlet
11 PH-3523	3 Amp. Fuse
12 ST-3092	10 Amp. Fuse
13 19006	Miniature Socket

No. 19705-A Power Distribution Panel Assembly

Part No.	Description
1 11555	Fuse Holder
2 17621	Power Rectifier
3 18859	Start Relay (D.C.)
4 18417	.01 MFD. 400 V. Condenser
5 15476	.002 MFD. 1200 V. Condenser

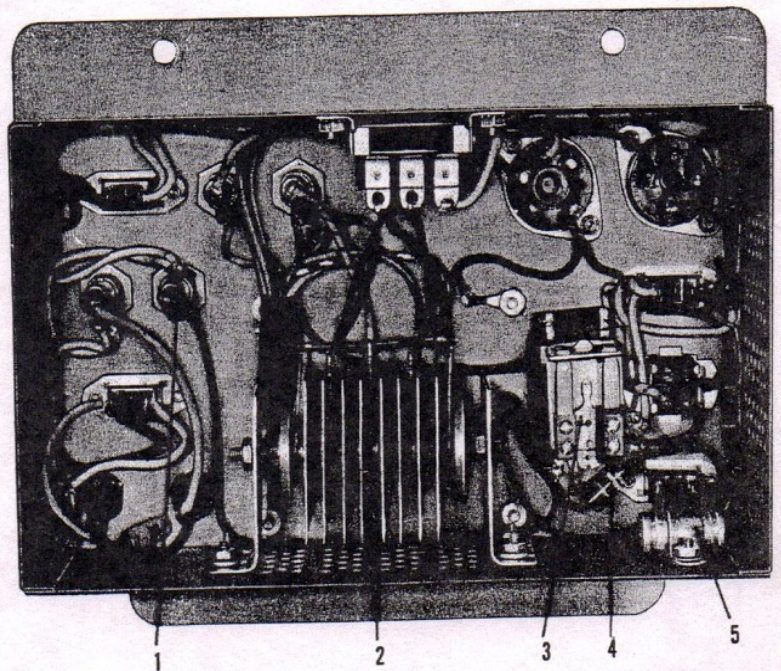

Additional Parts Listing

Part No.	Description	Part No.	Description
1 ST-3046	Type #44 Bulb	12 19726	10¢ and 3 for 25¢ Decal
2 ST-6028	Caster	13 19725	5¢ - 10¢ - 25¢ Decal
3 ST-7379	Cash Door Lock	14 19724	5¢ - 10¢ - 6 for 25¢ Decal
4 ST-7392	Rear Door Lock	15 18930	Cash Door Frame
5 ST-7394	Front Door Lock	16 18938	Cash Bag
6 12053	20 W. Fluorescent	17 19727	10¢ and 4 for 25¢ Decal
7 13362	Master Line Switch	18 19292	15" Hi-Fi Speaker
8 15159	Momentary Push Switch	19 19106-A	Volume Control Assembly
9 17008	Needle Brush	20 19614-A	Skid Front Casting Assem.(R.H.)
10 17804	Brush Wire	21 19615-A	Skid Front Casting Assem.(L.H.)
11 17958	Leveling Bolt	22 19172-A	Cash Door Assembly

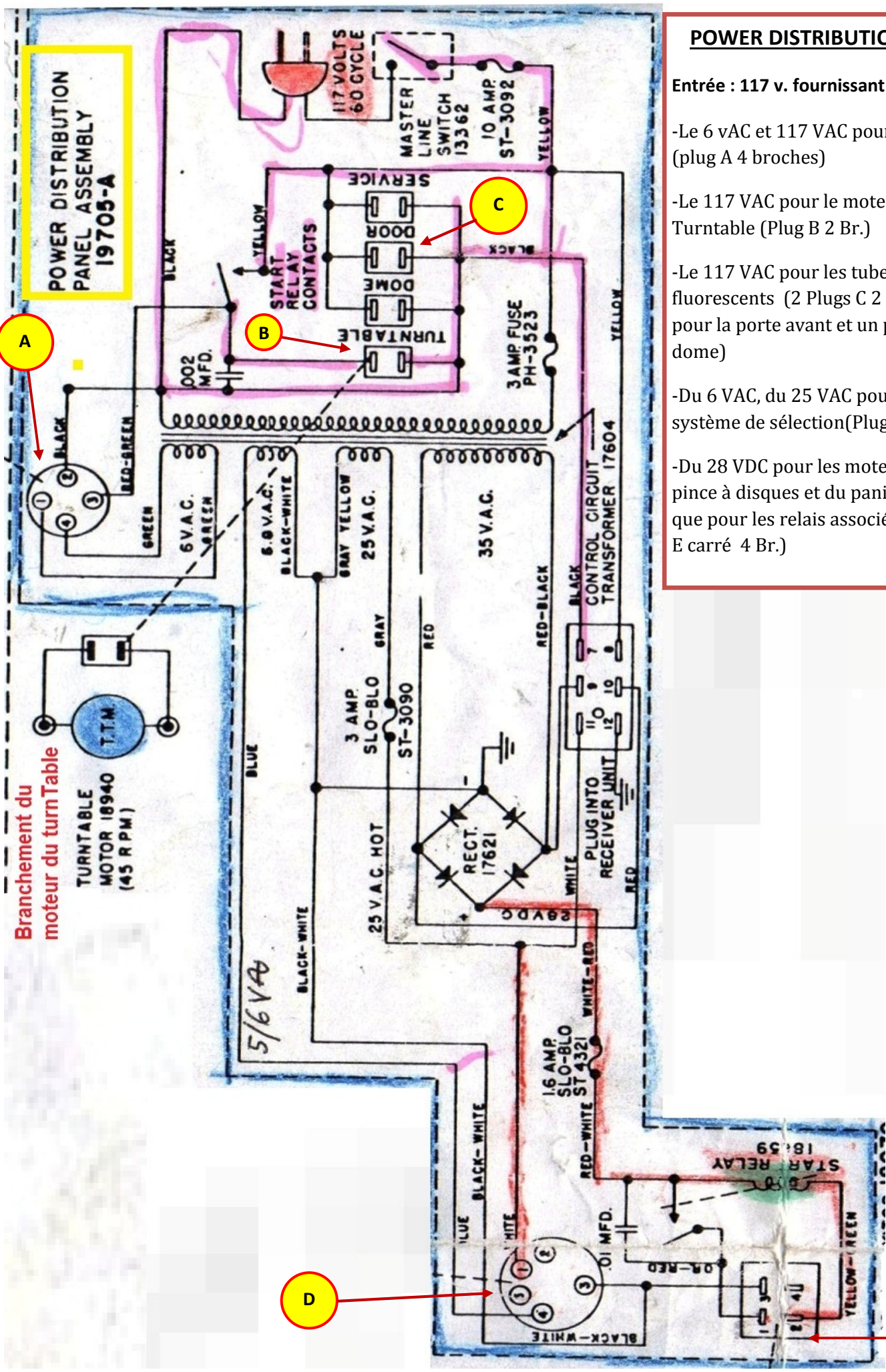

Branchement du  
moteur du turnTable

POWER DISTRIBUTION  
PANEL ASSEMBLY  
19705-A

**POWER DISTRIBUTION BIX**

- Entrée : 117 v. fournissant :
- Le 6 vAC et 117 VAC pour l'ampli (plug A 4 broches)
  - Le 117 VAC pour le moteur du Turntable (Plug B 2 Br.)
  - Le 117 VAC pour les tubes fluorescents (2 Plugs C 2 Br., un pour la porte avant et un pour le dome)
  - Du 6 VAC, du 25 VAC pour le système de sélection(Plug D 5 Br.)
  - Du 28 VDC pour les moteurs de la pince à disques et du panier ainsi que pour les relais associés (Plug E carré 4 Br.)

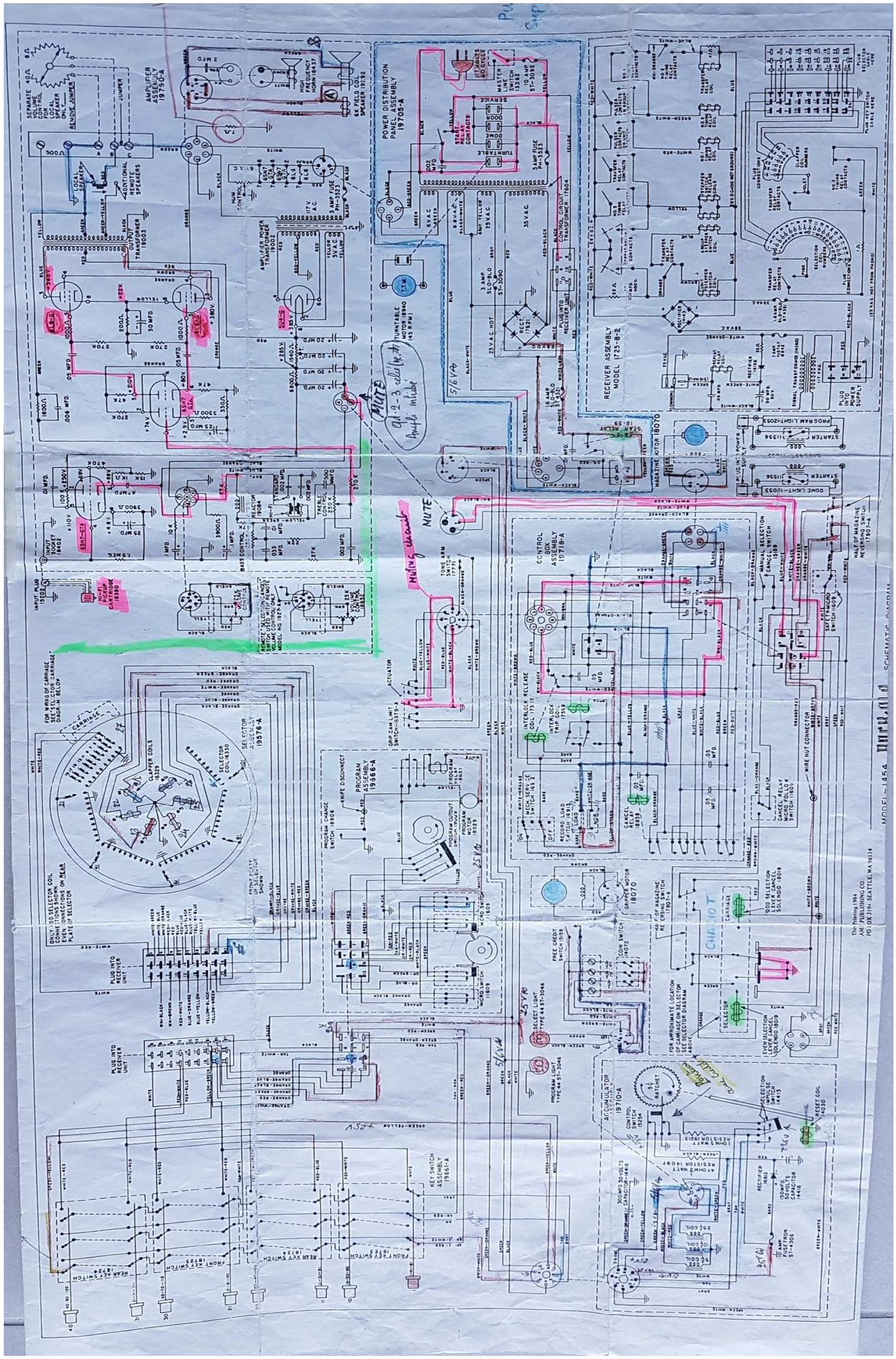

*MUTE*  
Q1-2-3 volts (p. 7)  
Amplitude indicator

*Muting circuit*

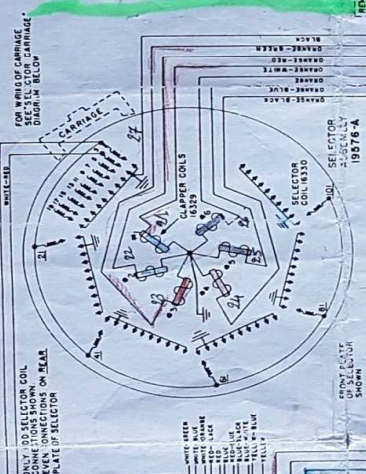

*Data Card*

MODEL-145A

The Pacific 1984  
AM PUBLISHING CO.  
PO BOX 319, SEATTLE, WA 98114